



ST3410

Operators Manual



Topcon Agriculture Americas
W5527 Hwy 106
Fort Atkinson, WI 53538
USA
Tel: 800-225-7695
E-mail: sales@digi-star.com

D4218-EN ST3410 Operators Manual Rev A

All rights reserved. Reproduction of any part of this manual in any form whatsoever without Digi-Star's express written permission is forbidden. The contents of this manual are subject to change without notice. All efforts have been made to assure the accuracy of the contents of this manual. However, should any errors be detected, Digi-Star would greatly appreciate being informed of these errors. The above notwithstanding, Digi-Star can assume no responsibility for errors in this manual or their consequence.

© Copyright! 2018 Digi-Star, Fort Atkinson (U.S.A.).

1.0 INTRODUCTION	5
2.0 ST3410 SPECIAL FEATURES.....	6
3.0 ACCURACY STATEMENT.....	7
4.0 TECHNICAL SPECIFICATIONS	8
5.0 SAFETY DURING USE	9
6.0 MANAGEMENT SOFTWARE.....	11
7.0 DATA TRANSFER FEATURES	11
8.0 INDICATOR OVERVIEW	12
8.1 Connections	14
9.0 OPERATION	15
9.1 Turn on Scale	15
9.2 Zero Balance Indicator	15
9.3 Tare and Net Gross	16
9.4 Select Seed/ Fertilizer type	18
9.5 Select Field	19
9.6 Select Planter/ Spreader Implement.....	20
9.7 Automatic Scale Mode Operation.....	21
9.8 Manual Mode	22
9.9 Print Key	23
9.10 Save Record Files to USB.....	24
10.0 Using BIN Functions.....	25
10.1 Selecting BIN	25
10.2 Viewing TOTAL Weight	26
10.3 Manually Entering BIN Weights.....	26
10.4 Clearing and Reloading BIN Weights.....	27
10.5 Number of BINs (BINNUM).....	27
11.0 AUTOMATIC MODE DISPENSING METHODS	28
11.1 Dispensing Options.....	28
12.0 OTHER FUNCTIONS	31
12.1 Preset	31
12.2 Clear Preset	31

12.3 Record Memory Check Percentage.....	32
12.4 Update Software/ Load Settings.....	33
12.5 Pre-Alarm (P-ALM)	34
12.6 Output Tolerance (OTOLER).....	34
12.7 Save Battery (AUTOFF).....	35
12.8 Count Size (COUNT).....	35
12.9 Hold	36
12.10 Display Dimmer	36
12.11 Setup Number.....	37
12.12 Calibration Number	37
12.13 Variable Throttle Settings	38
12.14 Serial Port Settings	39
13.0 SYSTEM SETUP	40
14.0 DIRECT ACCESS NUMBERS (D.A.N.).....	41
14.1 Options Changed by User.....	41
15.0 INSTALLATION.....	49
15.1 Indicator Mounting	49
15.2 Cable Connections	51
15.3 Auger Control Wiring	52
15.4 Connecting Load Cells to Junction Box.....	53
15.5 Load Cell Direction.....	54
16.0 OPTIONAL EQUIPMENT	55
16.1 Bluetooth Module	55
16.2 IPC Thermal Printer	55
16.3 Transmitter/Receiver.....	55
17.0 TROUBLESHOOTING FLOW CHART	56
18.0 NOTES	58
19.0 QUICK REFERENCE AID	59
20.0 DECLARATION OF CONFORMITY	61

1.0 INTRODUCTION

Thank you for your purchase of a Digi-Star ST3410 scale indicator. Your ST3410 is the culmination of more than 30 years of agricultural weighing engineering and expertise. With proper operation and preventative maintenance, the ST3410 will last for many years.

The Digi-Star ST3410 is primarily designed for weighing agricultural products during the loading and unloading of mobile and stationary bins. The ST3410 can be used with seed tenders, fertilizer carts, and other filling and dispensing applications.

The ST3410 is not for use with applications for which the ST3410 is not intended, or as outlined in this manual.

Use of the ST3410 outside of its intended purposes may result in inaccurate weight measurement or damage to instrument.

2.0 ST3410 SPECIAL FEATURES

The ST3410 is different from other scale indicators for several reasons. It is specifically designed for material dispensing and auto-shutoff applications, such as seed tenders, stationary bins, and fertilizer carts. When correctly wired and setup, the ST3410 can be configured to dispense a programmed weight by shutting off the operation once the weight is reached.

- Program in a PRESET weight by typing in the desired weight.
- Choose data records such as Field, Seed, Planter, Fertilizer, and Spreader.
- Choose which implement BIN or tank the weight is removed from.
- Detects when the dispensing/ unloading/ loading operation starts.
- Automatically shut off the machine unloading function. Single function solenoids, on/off type controls/ switches, and variable throttle modules can be controlled with correct wiring and control boxes.
- Save records to USB. Save and load settings through USB. Update software version through USB.

3.0 ACCURACY STATEMENT

READ THIS SECTION BEFORE USING THE SCALE SYSTEM

Digi-Star Scale Systems are designed and manufactured to provide the greatest accuracy possible. However, proper installation and use are required to obtain the highest level of accuracy.

When using the scale system, the following must be considered to realize the best possible performance and accuracy.

- Load cells must be installed with the proper orientation. Most Digi-Star load cells have a label indicating either the “TOP” or bending direction of the load cell. Inspect load cells to determine if the load cells are installed correctly. Incorrect installation of load cells will result in inaccurate measurement.
- Load cells should not be subjected to any strains or loads other than the weight of the load. Stress or strain caused by misalignment or other factors when accurate weight readings are desired will negatively affect the accuracy.
- The weighing unit should be stationary with minimum movement, and on a level surface, to ensure that weight readings are as accurate as possible.
 - The effect of movement on accuracy depends on the speed and roughness of the ground and application. Rougher terrain and faster and/or greater movement increases the degradation of accuracy.
 - A level surface is defined as being less than a 5” (13cm) change in rise over 10’ (3.0m) of run. As the slope of the terrain increases, degradation of accuracy will also increase.

4.0 TECHNICAL SPECIFICATIONS

SIZE	10.25" long x 8.0" high x 4" wide (260mm x 190mm x 105mm)
WEIGHT	4.5 lbs. (2.04 Kg)
HELP MESSAGES	Context sensitive help messages in 10 languages; Long messages scrolled
LOAD CELL EXCITATION	8 volts D.C. Nominal, Capable of driving ten 350 Ohms transducers, Short circuit proof
AUTO TEMPERATURE COMPENSATION	Of internal circuitry for high accuracy weighing measurements
LOAD CELL SIGNAL	Compatible with Load Cells with greater than 0.25 mv/v
CONNECTORS	AMP plastic weather resistant circular connector. Gold plated contacts.
POWER REQUIREMENTS	10.5 to 16.0 V.D.C. 160 mA nominal with four 350Ω load cells
SETUP & CALIBRATION	Entry via front panel or saved when downloading the setting files
GROSS RANGE	999,999 max-display
LOW BATTERY WARNING	Enabled at 10.5V nominal
POUND/KILOGRAM	Selectable
DISPLAY	6 Digit Chip on Glass LCD 1.7" high
DISPLAY RESOLUTION	.01, .02, .05, .1, .2, .5, 1, 2, 5, 10, 20, 50, 100
DISPLAY UPDATE RATE	Selectable: 1, 2, 3, 4 times/sec.
MAX. DISPLAY RESOLUTION	Adjustable to 40,000 counts max.
ZERO TRACKING	Selectable, On/Off
SPAN ACCURACY	± (.1% + .005%/ °F) or (.1% + 0.009% °C) full scale ± 1 output count
MOTION DETECTION	Selectable, On/Off
ZERO ACCURACY	(.005%/ °F) or (0.009% °C) full scale ±1 output count for 0.5 mv/v transducer
ENVIRONMENTAL ENCLOSURE	IP65, IEC 529
WEIGH ALGORITHM	3 internally selectable digital filters to optimize performance (General, Slow, and Fast)
HOLD MODE	Stabilize displayed weight while moving the scale
NON-VOLATILE MEMORY	Standard
OPERATING TEMP	-29 °C to 60 °C (-20 °F to 140 °F)
RELAY OUTPUT	Drives up to 9.0A at system voltage; configurable software settings
2 REMOTE INPUTS (Power/Remote ports)	TARE /PRINT / HOLD / NETGRS / M+ / ZERO / TR HLD / PRESET / SWITCH/ INGRED/ SEEDTD/ ST STP/ MIXCTR

5.0 SAFETY DURING USE



Danger: Indicates an imminently hazardous situation that, if not avoided, could result in death or very serious injury.



Warning: Indicates a potential hazardous situation that, if not avoided, may result in death or very serious injury.



Caution: Indicates a potential hazardous situation that, if not avoided, may result in a minor injury.

IMPORTANT! Signals special mechanical information

Exposure to Radio Frequency

Exposure to energy from radio frequencies is an important safety issue. As this product uses the WiFi and Cellular system of a smartphone or tablet please consult with the safety information provided with the device that the App operates with.

Prior to Operation

Read and understand this manual and learn all controls before you use the equipment. Check that the area is clear of people, animals, and obstacles before starting any work. Identify possible hazards.

Check system before use

Digi-Star cannot be held responsible for deviations and problems arising from incorrect use of the ST3410, incorrect calibration, or settings. Furthermore, Digi-Star cannot be held responsible for deviations and problems arising from technical problems to the system.

IMPORTANT!

Cleaning:

Do not use pressurized running water (high pressure cleaners, hoses nozzles, etc.) to clean the indicator. Water ingress and damage to the indicator may result. Use soapy water and a sponge or cloth for best results.

Battery Charging and Welding

Disconnect all cables from the scale indicator before charging the battery or welding on the machine. If cables are left connected, the scale indicator, optional devices, and connected load cells could be damaged. It is also recommended to not place the welding ground so that welding current and voltage flows through any load cells. Secure the welding ground to prevent welding current and voltage from flowing through load cells.

ST3410 Machine Operation

The ST3410 is designed to operate the conveyor/ auger and other controls as an auto-shutoff system. As this operation may activate parts of the machine, all maintenance or adjustments to the machine should be done with the machine turned off. A change in ST3410 settings or other connected electronic equipment may change the machines behaviour. Follow all machine manufacturer guidelines.

ST3410 Manual Bypass

The ST3410 is designed to be used with an external control box which includes an AUTO/ MANUAL switch. Use of the ST3410 without a correctly wired manual bypass switch installed is outside of its intended design.

MANUAL mode is intended to return the machine to its original or factory controls, bypassing the ST3410 control features. By bypassing the ST3410, the machine is controlled by the user and the factory machine controls. Variable throttle control boxes are designed in a way that allows the user to maintain control of the engine/ conveyor throttle, and only reduces the throttle of the machine.

6.0 MANAGEMENT SOFTWARE

PC Software – Future

Wireless Application – Future

7.0 DATA TRANSFER FEATURES

USB Port







Download user and load data from indicator to USB drive. Also used to upload field, seed/ fertilizer, and planter/ spreader information onto indicator.









Software updates and settings load can be performed with USB port.

Wireless – Future

8.0 INDICATOR OVERVIEW



- ①  - Press and hold for three seconds to zero balance.
- ② **Pre-Alarm Light** - Starts flashing and alarm sounds when weight is within preset limit.
- ③  - Holds displayed weight when moving machine
- ④  - Start or stop load/unloading operation.
- ⑤  - Turns indicator on. Pressing while on will run self-test.
- ⑥  - Turns scale indicator off.
- ⑦ **Display Window** - Displays current actions.
- ⑧  - Press TARE button for temporary zero when adding more weight.
- ⑨  - Prints displayed weight.

- ⑩  – Toggles between NET and GROSS weights.
- ⑪  – Selects BINs in memory, program BIN weights.
- ⑫  – Enter and exit Field screen.
- ⑬  – Enter and exit Seed / Fertilizer screen.
- ⑭ **Directional Arrows** – Moves through list of information. Left arrow (-) and right arrow (+).
- ⑮  – Accepts change or proceeds to next item.
- ⑯ **Numbers Keypad** – Type in PRESET weight, DAN codes for changes.
- ⑰  – Exits current function or key presses back to main screen.
- ⑱  – Performs tasks displayed when using the select button.
- ⑲  – Display additional tasks for the user.
- ⑳  – Shows additional information for last key pressed.

8.1 Connections

STANDARD CONNECTION

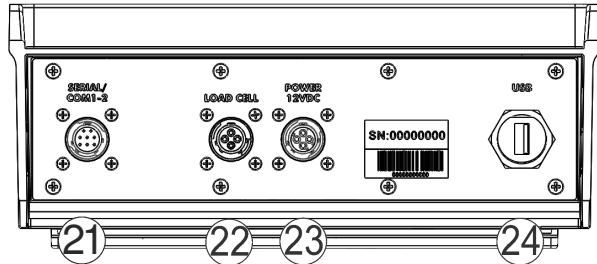

EZ MATE CONNECTOR, OPTIONAL

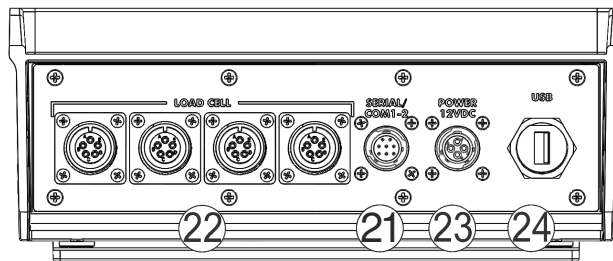
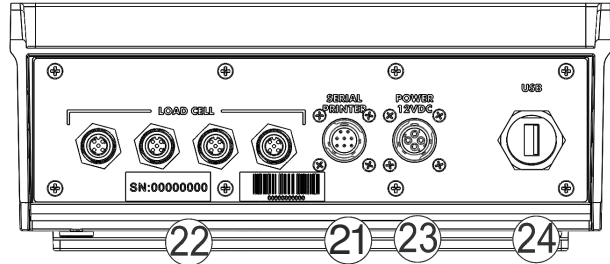



CROWN CONNECTOR, OPTIONAL

- ① **Serial/Printer Port** – Communicate with computer and other digital input/output devices.
- ② **Load Cell Port** – For (Standard) or individual load cell connections (EZ Mate/ Crown).
- ③ **Power Port** – For control box with cord.
- ④ **USB Port** – For downloading software, settings, or data.

9.0 OPERATION

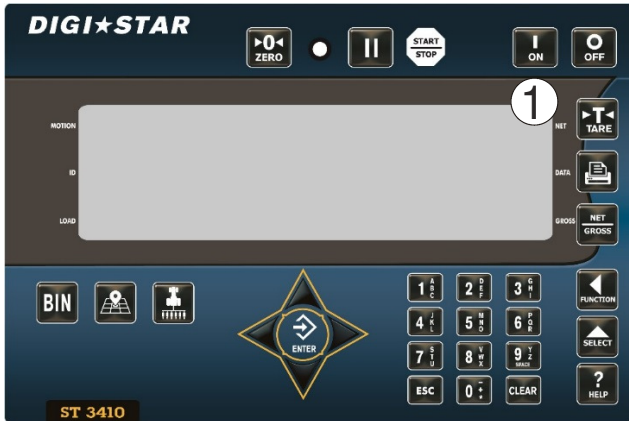
9.1 Turn on Scale



1. Press .

9.2 Zero Balance Indicator



1. Press and hold  for three seconds to zero balance indicator.
2. Indicator ready to weigh when flashing arrow points to Gross.

9.3 Tare and Net Gross

Tare is a temporary zero (Net Weight) to display total Weight (Gross Weight) Press  .



1. Starting weight displayed.
Example: 4000

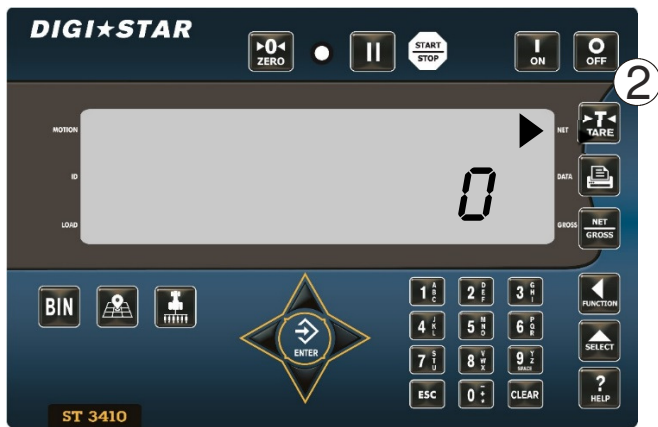

2. Press  to set weight to zero.
3. Flashing arrow points to NET.



4. Add more weight.
Example: 300



5. Press **NET GROSS** to show GROSS weight of starting weight of 4000 pounds, plus added 300 pounds.

Flashing arrow points GROSS.



6. Press **NET GROSS**. 300 pounds displayed, flashing arrow points NET.

9.4 Select Seed/ Fertilizer type

The ST3410 can track SEED and FERTILIZER data.



1. Press .
2. Press Left or Right arrows to select between SEED and FERT commodity.
3. Press UP and DOWN arrows to scroll through list. (Example; SEED 1–SED150). SEED and FERT are 6 characters maximum.



NOTE 1: Typing a number while in the list and pressing enter jumps to that SEED/ FERT number.

4. Press  to select.





NOTE 2: Text for SEED/ FERT name can be changed.

- A. Select SEED number, steps 1-3 above.
- B. Press and hold ENTER until number flashing.
- C. Press CLEAR.
- D. Type 6-digit name.
- E. Press ENTER to save.
- F. Press ENTER again to go back to weight.

9.5 Select Field

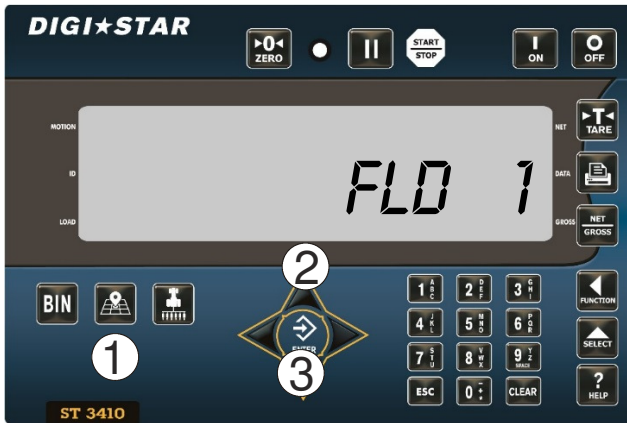
The ST3410 can track FIELD data.



1. Press .
2. Press UP and DOWN arrows to scroll through list. (Example; FLD 1 – FLD150). FIELD is 6 characters maximum.

NOTE 1: Typing a number while in the list and pressing enter jumps to that FIELD number.

3. Press  to select.





NOTE 2: Text for FIELD name can be changed.

- A. Select FIELD number, steps 1-2 above.
- B. Press and hold ENTER until number flashing.
- C. Press CLEAR.
- D. Type 6-digit name.
- E. Press ENTER to save.
- F. Press ENTER again to go back to weight.

9.6 Select Planter/ Spreader Implement

The ST3410 can track PLANTR/ SPREAD implement data.



1. Press  until PLANTR or SPREAD is shown.
2. Press  to confirm.
3. Press Left or Right arrows to select between PLANTER and SPREADER implement.
4. Press UP and DOWN arrows to scroll through list. (Example; PLT 1–PLT150). PLT and SPRD are 6 characters maximum.

NOTE 1: Typing a number while in the list and pressing enter jumps to that PLT/SPRD number.

5. Press  to select.

NOTE 2: On screen editing for PLANTER/ SPREAD is not available.

9.7 Automatic Scale Mode Operation

ST3410 Indicator Controls Shutoff.

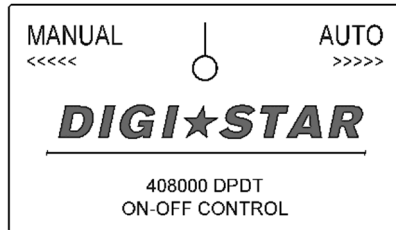

1. Verify Control box switch is set to AUTO.

NOTE: Control box type may vary, standard control shown.

2. Press **BIN**.
3. Press UP and DOWN arrows to view bins.

NOTE 1: Typing a Bin number in the BIN screen and pressing  jumps to that bin number.

4. Press  or **BIN** to select the displayed Bin.

NOTE 2: Bin function is disabled when BINNUM is set to 1. See DAN 6601 to enable BIN function.

NOTE 3: Pressing **CLEAR** cancels changes to currently selected BIN.

5. Verify correct field, seed/ fertilizer, and planter/ spreader are selected.
6. Determine weight to fill each tank or hopper.
7. Use keypad to enter PRESET weight.
8. Press  to store. Display will show PRESET STORED.



9. Move seed tender chute/ fertilizer dispenser to tank/ hopper.
10. Dispense material to tank/ hopper using methods from Section 11. Weight on screen will count down.
11. Auger/ conveyor will turn off when reaching PRESET weight.
12. Repeat steps until all tanks/ hoppers are filled. ST3410 will continue with last values entered.

9.8 Manual Mode

Operator controls material dispensing; Indicator monitors weight.

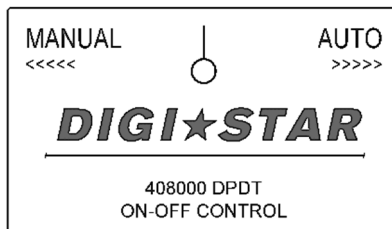

1. Verify control box switch is set to MANUAL.
2. Follow manufacturer's instructions to operate implement.
3. Operator controls material dispensing and shutoff. ST3410 displays weight.

NOTE: Control box type may vary, standard control shown.

9.9 Print Key

Print key sends current display weight and user factors to a printer or PC application at each press.



1. Press 

NOTE 1: ST3410 prints/ sends data at the end of each PRESET cycle when a PRESET is completed, no key presses needed.

NOTE 2: Use DAN 6308 to delay print time after PRESET for more accurate unload data.

NOTE 3: Use DAN 2304 to select print format. 2 examples shown.

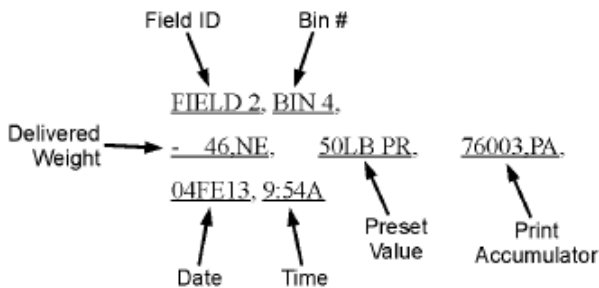

NOTE: Print format PRTST3 shown.

Seed/ fertilizer cart print formats:
PRTST1
PRTST3
PRTST5

NOTE: Print format PRTST5 shown.

This format includes seed/fertilizer, planter/ spreader, delivered weight, and field data.

Example :

```

1          2          3
12345678901234567890123456789012345

BIN  1,                -> Bin name
SEED 1,               -> Seed/Fertilizer
150LB PR,            -> Preset Target Weight
PLT  1,19JA17, 10:47A -> Planter/Spreader, Date, Time
- 148,NE, 1492,PA    -> Delivered Weight, BIN Accumulator
FLD   1              -> Field name
    
```

9.10 Save Record Files to USB

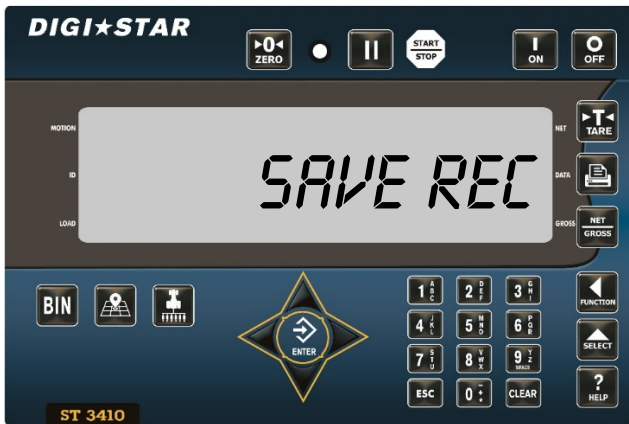

1. Insert USB in bottom of ST3410 indicator.
2. Message displayed, "PRESS ENTER TO SAVE RECORDS...".
3. Press .
4. After files are saved to USB, "REMOVE USB".

NOTE 1: When record storage is 90% or higher, message of 'RECORDS 90% FULL' displays at power up of indicator.

NOTE 2: When record storage is at 100%, message of 'RECORD MEMORY FULL—DOWNLOAD RECORDS' is displayed.

Upload records to PC program – Future

Transfer Field, Seed/ Fert, and Plantr/ Spread names from PC to ST3410 – Future

10.0 Using BIN Functions

NOTE: BIN function is disabled when BINNUM is set to 1. See DAN 6601 to enable BIN function.

10.1 Selecting BIN

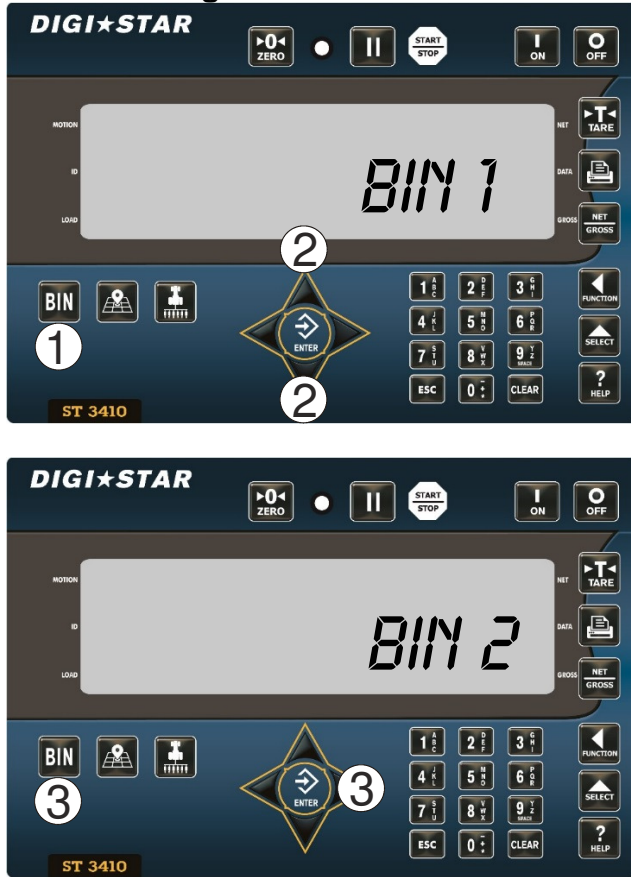

1. Press **BIN** to display active implement bin. The display will show BIN XX for the active bin.
2. Press UP and DOWN arrows until desired bin is displayed.

NOTE 1: Typing a BIN number in the BIN screen and pressing **ENTER** jumps to that BIN number.

3. Press **BIN** or **ENTER** to confirm selection.

The display will alternate between BIN XX and weight.

NOTE 2: When a BIN is selected, only the selected BIN and TOTAL weight values change. The other BIN values do not change until selected.

10.2 Viewing TOTAL Weight



1. Repeatedly press until TOTAL is displayed.
2. Press ; total of all BIN weights will display for two seconds.

10.3 Manually Entering BIN Weights

Assign known weight to BIN memory.



1. Press . Press UP and DOWN arrows to select BIN.
2. Press to select.
3. Type in known BIN weight with keypad.
4. Press to store. "BIN XX STORED" will be displayed.



Example:

1300 pounds is known weight loaded into BIN 4.

Press , then press UP/ DOWN arrows until BIN 4 displays. Press "ENTER" to confirm. Type the weight, 1300.

Press to store. "BIN 4, 1300" alternating on display.

NOTE: BIN weight can still be stored when BINNUM set to 1. *No confirmation message displayed.

10.4 Clearing and Reloading BIN Weights

Clears each BIN weight before loading seed tender/ fertilizer cart.



1. Press **BIN**. Press UP and DOWN arrows to select BIN.
2. Press **ENTER** to select.



3. Press and hold **ZERO** to clear BIN weight.
4. Load material into tank/ hopper BIN. Displayed weight is BIN weight.
5. Repeat process for clearing and loading other BINs.

10.5 Number of BINs (BINNUM)

Program number of implement bulk bins.



1. Type 6601, press **SELECT**.
2. Press up/ down arrows for number of implement bins.
3. Press **ENTER** to save.

*2 is factory default.

**Set to 1 (off) if not using individual BIN weights.

11.0 AUTOMATIC MODE DISPENSING METHODS

11.1 Dispensing Options

The following methods may be used to dispense materials/ commodities while in AUTO mode. Please note that not all methods may be available on your seed tender/ fertilizer cart model. In all methods, display will alternate between PRESET and remaining weight. Auger/ conveyor will turn off automatically when reaching PRESET weight.

Option 1



Press  on indicator.

NOTE: Not applicable to variable throttle shutoff models. Use option 2 or 3 to start dispensing.

Option 2



Press wired button or throttle switch on cart.

Refer to Implement Manual for details.

Option 3



Press speed increase/ throttle up button on wireless implement control.

NOTE: This may be a toggle switch, momentary button, 2 buttons for conveyor ON/OFF, or Fast/ Slow throttle controls.

Refer to Implement Manual for details.

NOTE: The manufacturer's auger/ conveyor button may need to be pressed 2 times to unlock and fill the next hopper/ tank on a standard On/ Off or hydraulic control.

1. Press once to disengage or reset OEM controls.
2. Press again to dispense material. Some radio models may require an 'Auger OFF' type of button to be pressed first, before pressing 'Auger ON' to restart the system at each hopper/ tank fill.

Option 4



Press optional Digi-Star TR Transmitter button.

NOTE: Not applicable to variable throttle shutoff models. Use Option 2 or 3 to start dispensing.

Tips and practices for best accuracy

In order to achieve the greatest accuracy in dispensing material weight, fill the hoppers/ tanks in the most consistent manner as possible.

- Dispense material on level ground.
- Avoid areas of high wind.
- Fill all hoppers/ tanks in the same manner. The auger/ conveyor and chute will hold more material when fully extended than when vertical, and may change the weight of the material dispensed.
- When filling with a fully extended chute, the output tolerance (OTOLER DAN 6306) may need increasing, compared to filling the same implement with a short chute.
- The dispensing chute should rest on or against the hopper/ tank the same way for every fill.
- Do not let the chute hang free or rest on the material as it is filling.
- For fast moving augers/ conveyors, a restrictor plate may be required from your implement manufacturer/ dealer to better control the dispensing rate.
- When using individual boxes such as Pro Boxes, adjust the slide door to slow down the dispensing rate if needed.
- Adjust the tolerance for the commodity type being used.

12.0 OTHER FUNCTIONS

12.1 Preset

The PRESET feature is used to fill tanks/ hoppers to a programmed weight. This is used as the auto shut-off target weight.



1. Type desired preset weight.

2. Press .

Indicator rounds weight to nearest display count and displays PRESET STORED.

12.2 Clear Preset

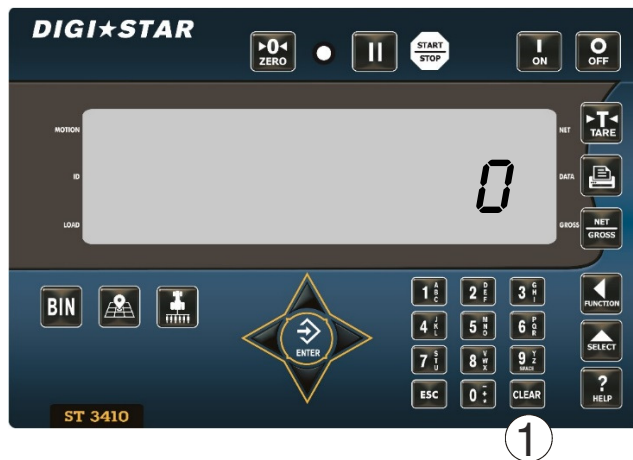



1. Press  to clear an active preset.

Auto shutoff is not activated.
No data is printed/ stored.

Use for clearing a preset that was started unintentionally, where no data record is needed.

12.3 Record Memory Check Percentage







1. Press  until RECMEM is displayed.
2. Press .

NOTE: To check record memory, will be displayed, 0% to 100% full.

12.4 Update Software/ Load Settings







1. Copy software from email or PC onto blank USB. File name must be "image.S19".
2. Press  until SV SET is displayed. Hold .
3. Insert USB at prompt. Settings will save to USB.
4. Remove USB and turn OFF.
5. Hold ON for 6 seconds until BTLDR is displayed.
6. Insert USB. ST3410 will update software.
7. Remove USB and turn OFF.
8. Turn ON, wait for main screen.
9. Press  until LD SET is displayed. Hold .
10. Insert USB. ST3410 will load settings. Remove USB.

12.5 Pre-Alarm (P-ALM)

Selects method and value to active early warning before reaching preset.





1. Enter 4001 press .
2. Press  again to choose between WEIGHT and PERCENT.
3. Press  to save.
4. Enter Pre-Alarm value.
5. Press  to save.

NOTE: Use DAN 4002 to change just the P-ALM value.

12.6 Output Tolerance (OTOLER)

Sets weight offset for under or over fill of commodity.



1. Enter 6305 and press .
2. Set OTMTHD to WEIGHT.
3. Press  to save.
4. Set OTOLER to desired weight with keypad.

Default is 20. See Section 13 for how to determine a closer value.



5. Press  to save.

NOTE: Use DAN 6306 to change just the OTOLER value.

12.7 Save Battery (AUTOFF)

Indicator turns off at programmed time.



1. Type 1007 and press ; AUTOFF briefly displays followed by OFF or time.
2. Repeatedly press  to set time 15, 30, 45, or 60.
3. Press  to save.

12.8 Count Size (COUNT)

Sets displayed count size.



1. Type 3001 and press ; COUNT briefly displays followed by count value.
2. Repeatedly press  or up/ down arrows to set count size.

NOTE: Count size should match load size. If unloading 2000lbs, a count of 10 or 20 works. Unload 150lbs, a count size of 5 works.



Too low of count size may cause the ST3410 to appear unstable with wind or small weight changes.

3. Press  to save.

12.9 Hold

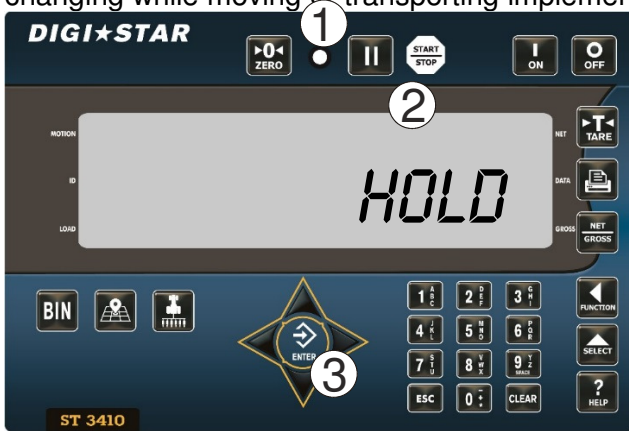
Hold mode prevents displayed weight from changing while moving or transporting implement.





1. Press  to enter Hold Mode.
2. Press  to return to Normal Mode.
3. If weight added in hold mode, press  to cancel hold.

12.10 Display Dimmer



Display backlight has 2 brightness settings.



1. Repeatedly press  until DIMMER is displayed.
2. Press  to dim backlight.
3. Repeat steps 1 and 2 to change backlight back to previous state.

12.11 Setup Number



1. Enter **8711**
2. Press 
3. Current setup number will be displayed.
4. Enter new setup number using keypad.
5. Press  to store.

12.12 Calibration Number



1. Enter **8712**
2. Press 
3. Existing calibration number will display.
4. Enter new number using keypad



NOTE: Press and hold  key for two seconds to clear all numbers.

5. Press  to store.

12.13 Variable Throttle Settings

PAST sets how long the Auto shutoff time lasts. Setting is designed for variable throttle controls.



1. Type 6303 and press ; PAST briefly displays followed by seconds.
2. Use arrows or type in time in seconds for implement to fully throttle down. Can set to 0.1 second increments. Default of 4.0.
3. Press  to save.

NOTE 1: Your ST3410 should be setup in the correct mode with these variable throttle settings from the factory. Settings are here for reference and troubleshooting.

Variable Throttle Reference Settings:

STTHRO: DAN 6613 = ON

RELAY: DAN 4005 = PRNOPA

RMINP1: DAN 1401 = SEEDTD

PAST: DAN 6303 = Time to throttle down from full throttle. Increase value if machine/ conveyor throttle is still above idle after an unload cycle. Increase value and retest. Default 4.0 seconds.

Test with empty implement:

Type in PRESET of 50, control box set to AUTO, increase to full throttle, verify PRESET started on ST3410, press STOP on ST3410. Should go back to idle then display PRINT.

NOTE 2: Your variable throttle model ST3410 gives the operator the ability to adjust the throttle during the unload cycle to control the dispensing rate, without cancelling the PRESET. Once the target PRESET weight is reached, the ST3410 activates the auto shutoff function for the PAST time programmed, regardless of the actual throttle position.

12.14 Serial Port Settings

The ST3410 has many RS232 serial port settings available. Refer to D4055 “10/60 Series Technical Manual” for details. Basic connections and settings are listed here for reference.

Circular Serial Port Connector:

Pin	Description
1	Current Loop (+)
2	Com # 1 Out (Tx)
3	Com # 1 In (Rx)
4	Com # 2 Out (Tx)
5	+12 VDC (F1 fuse 2.5A)
6	GND
7	Com # 2 In (Rx)
8	GND

COM 1 BAUD RATE (C1 BD)	2201	Sets baud rate for com port #1
COM 1 PARITY (C1 PA)	2202	Sets parity for com port #1
COM 1 DATA BITS (C1 DATA)	2203	Sets data bits for com port #1
COM 1 DELAY (C1 DLY)	2204	Selects seconds to delay before advancing to next line.
COM 2 BAUD RATE (C2 BD)	2211	Sets baud rate for com port #2
COM 2 PARITY (C2 PA)	2212	Sets parity for com port #2
COM 2 DATA BITS (C2 DATA)	2213	Sets data bits for com port #2
COM 2 DELAY (C2 DLY)	2214	Selects seconds to delay before advancing to next line.

13.0 SYSTEM SETUP

Number of Bins, BINNUM (D.A.N. 6601)

Enter number of implement bulk bins. Refer to Section 10 for details, DAN 6601.

Output Tolerance, OTOLER (D.A.N. 6306)

Enter output tolerance weight. Refer to Section 10 for details, DAN 6306. Default 20lbs.

Unload Delay, UDELAY (D.A.N. 6308)

Delays print/ data record time after PRESET for more accurate unload data, DAN 6308. Increase value if ST3410 displays PRINT while commodity is still dispensing.

Calculating Output Tolerance

Output tolerance is the weight offset of commodity remaining in the auger/ conveyor chute while filling the planter/ spreader. This value is set to adjust for the time of movement of material sliding out of the dispensing chute. This value may need to change based on chute size, extended chute length, commodity type, and commodity weight. Set the "OTOLER" value for the expected use of the dispensing implement.

1. Load at least 250 pounds of seed/ fertilizer into the implement.
2. Park implement on level ground.
3. Collect three empty buckets or barrels of same size and weight to hold at least 80 pounds of seed/ fertilizer each.
4. Have another scale nearby that can measure one full bucket (scale 2).
5. Weigh empty bucket on scale 2 and record the bucket weight for later.
6. Enter PRESET of 50 pounds on indicator. 5-0-ENTER.
7. Extend chute to normal distance and height of a normal fill.
8. Dispense seed/ fertilizer in AUTO mode into one empty bucket. See Section 9.7, Automatic Scale Mode.
9. Weigh the filled bucket on scale 2.
10. Subtract the PRESET target weight (50) from scale 2 full bucket weight.
11. Subtract bucket empty weight.

<u>Method:</u>		<u>Example:</u>
Total filled bucket	72	pounds (Bucket with seed/ fertilizer)
-50lb PRESET	-50	pounds (PRESET target number)
- Bucket	-5	pounds (Bucket, step 11)
= OTOLER Weight	=17	pounds (OTOLER DAN 6306).







12. Enter weight value as "OTOLER", DAN 6306.
13. Repeat steps 7-12 on other two buckets to verify accuracy.

NOTE: For an implement dispensing too much seed/ fertilizer, increase OTOLER by the amount of overfill. For implement dispensing too little seed/ fertilizer, decrease OTOLER.

14.0 DIRECT ACCESS NUMBERS (D.A.N.)

14.1 Options Changed by User

To display menus 1, 2, 3, 4, 5, 6 and 7:

1. Repeatedly press  until MENU is displayed.
2. Press and hold .
3. Repeatedly press  to select Menus 1, 2, 3, 4, 5, 6, or 7.
4. Press  displays setting name and allows value changes.
5. Press either  or  to scroll through options for each setting/display.
6. Press  to save setting and next option for menu displays.

SETTING [display]	D.A.N NO.	OPTIONS [displayed] BOLD=DEFAULT	DESCRIPTION	
MENU 1 - GENERAL SETTINGS				
LANGUAGE [LANGAG]	1001	English Dutch French German Italian Portuguese Spanish Danish Hungarian Spanish Polish	[ENGLISH] [DUTCH] [FRANCS] [DEUTSH] [ITAL] [PORT] [ESPAÑ] [DANSK] [MAGYAR] [HUNGAR] [POLSK] [POLSK]	Select language to be displayed.
DISPLAY RATE [DRATE]	1002	1,2,3,4,6,7,8,9,10	Update display times per second.	
SCALE ID SETUP [SCALID]	1003	NEW EZ	Identity of scale location (truck id or Mixer number).	
ZERO TRACK [ZTRACK]	1004	ON/OFF	If ON -zero track adjust balance for buildup of snow & mud.	
WEIGH METHOD [W MTHD]	1005	1=General 2=Fast 3=Slow	Select weigh method. The speed the weight changes as shown on the LCD.	
1 PRESS ZERO [1 ZERO]	1006	ON/OFF	If ON -press and hold Zero key to Zero/Balance scale.	
AUTO OFF [AUTOFF]	1007	OFF, 15, 30, 45, 60	Indicator turns off after selected minutes of stable weight.	

SETTING [display]	D.A.N NO.	OPTIONS [display] BOLD=DEFAULT	DESCRIPTION
DISPLAY UNIT [LB-KG]	1008	LB/KG	Display pounds – LB or Kilograms - KG
SCROLL DELAY [SCROLL]	1101	0,1,2,3,4, 5, 6, 7, 8, 9	Scroll rate for cold temperatures 0=normal 9=slowest
SAVE TARE [SAVTAR]	1102	ON/OFF	Saves tare weight to non-volatile memory.
PRELOAD TARE [PRETAR]	1103	ON/OFF	Tare weights can be entered using the numeric keypad.
TIME FORMAT [TIME F]	1201	24 HR AM/PM	Select time format -AM/PM or 24 hours
TIME [TIME]	1202	XX:XX:XX, AM/PM	Enter changes hh:mm:ss (use numeric keypad) use function key to change between hh:mm:ss. Then choose AM/PM.
DATE FORMAT [DATE F]	1203	1-mm-dd 2-mm/dd/yy 3-mm/dd/yyyy 4-dd-mm 5-dd/mm/yy 6-dd/mm/yyyy 7-ddmmyy 8-ddmmyyyy	Select date format
DATE [DATE]	1204	Enter ddmmyy	Select key changes date or numerical keys -function key chooses dd/mm/yy.
DATE CHECK [DT CHK]	1205	ON/OFF	Verifies the real time clock has a valid date at power up.
REMOTE INPUT 1 [RAINP1]	1401	TARE, PRINT, HOLD, M+, ZERO, MIXCTR, TR HLD, ST STP, SEEDTD , OFF, PRESET, SWITCH	Sets function of remote input line on the power cord. ST STP for standard control SEEDTD for variable throttle
REMOTE INPUT 2 [RAINP2]	1411	TARE, PRINT, HOLD, M+, ZERO, MIXCTR, TR HLD, ST STP, SEEDTD , OFF, PRESET, SWITCH	Sets function of remote input line on the remote port.
PROGRAM ID [PRG ID]	1998		Displays current software version
ESTIMATED WEIGHT [EST WT]	1999	Enter weight value using key pad. Then press enter.	Manually adjust Gross weight of scale by changing zero/balance. Press “on” to continue.

SETTING [display]	D.A.N NO.	OPTIONS [display] BOLD=DEFAULT	DESCRIPTION
MENU 2 - COMMUNICATIONS FEATURES			
REMOTE <i>[REMOTE]</i>	2001	ON/OFF	If ON indicator communicates with Cab Control Display
SCALE NUMBER <i>[SCL NO]</i>	2002	1,2,3,4,5,6,7,8,9,10,11,12, 13,14,15,16,17,18,19,20, 21,22,23,24	Select scale number for cab control communication
EXTERNAL RADIO <i>[EXTRAD]</i>	2003	ON/OFF	Enables external radio to be connected to the J905 port.
DDL ATTACHED <i>[DDL]</i>	2004	YES/NO	Enables connection of a DDL (Data DownLoader)
EZ2 AUDIBLE COMMANDS <i>[EZ2AUD]</i>	2005	ON/OFF	Enables audible sound when EZII command sent.
SCOREBOARD MODE <i>[SCOREM]</i>	2101	0,1,2,3,4,5,6,7,8,11,12,15, 27,37,38,39	Select scoreboard output
ZERO OUTPUT <i>[ZEROUT]</i>	2102		Allows zero/balance for SCOREM #11 serial gross weight.
FRONT PANEL ZEROUT <i>[ZEROFFP]</i>	2103	OFF/ON	Allows use of the zero key to zero/balance the serial gross weight.
SCOREBOARD 2 <i>[SCOREM2]</i>	2104	0,1,2,3,4,5,6,7,8,11,12,15, 27,37,38,39	Select scoreboard 2 output
OPERATION STATUS <i>[OPSTAT]</i>	2111	0, 2	Select operating data to be sent to a Remote Terminal
-DVADJ	2199	ON/OFF	Causes the – sign to be left justified
COM 1 BAUD RATE <i>[C1 BD]</i>	2201	1200,2400, 4800, 9600 , 14400, 19200, 38400, 57600, 115200	Sets baud rate for com port #1
COM 1 PARITY <i>[C1 PR]</i>	2202	NONE, ODD, EVEN	Sets parity for com port #1
COM 1 DATA BITS <i>[C1 DATA]</i>	2203	7, 8	Sets data bits for com port #1
COM 1 DELAY <i>[C1 DLY]</i>	2204	0, .10, .25, .50, .75, 1-5	Selects seconds to delay before advancing to next line.
COM 2 BAUD RATE <i>[C2 BD]</i>	2211	1200,2400, 4800, 9600 , 14400, 19200, 38400, 57600, 115200	Sets baud rate for com port #2

SETTING [display]	D.A.N NO.	OPTIONS [display] BOLD=DEFAULT	DESCRIPTION
COM 2 PARITY [C2 PA]	2212	NONE , ODD, EVEN	Sets parity for com port #2
COM 2 DATA BITS [C2 DATA]	2213	7, 8	Sets data bits for com port #2
COM 2 DELAY [C2 DLY]	2214	0 , .10, .25, .50, .75, 1-5	Selects seconds to delay before advancing to next line.
TARE AUTO PRINT [TAREAP]	2301	ON/ OFF	If ON -tare auto-prints displayed weight.
ONE LINE PRINT [1L PRT]	2302	ON/ OFF	If ON -indicator data prints on one line.
AUTO PRINT [APRINT]	2303	ON/ OFF	If ON -pressing keys auto-prints weight values.
PRINT FORMAT [PRTFMT]	2304	AUTO, WTONLY, DOWNLD, DT+TM, ID+TM, IDWTTM, BATCH1, PRTAC1, PRTAC2, PRTAC3, PRWTRC, WTRCTM, 3200-A, 3200-B, SCLABC, PRTAC4, PRTAC5, PRTAC6, PRTST1, PRTST3, PRTST5 , RECINF	Select alternate & comma (CSV) print formats.
PRINT ACCUMULATION [PRTACC]	2305		Shows running total of weights printed for selected FIELD
REMOTE DISPLAY [RDISP]	2401	EZ2 , EZ3MUX, COG, NONE	Select type of remote display
REMOTE TERMINAL [RATERM]	2402	ON/ OFF	Sends display data to serial remote terminal interface
BAR GRAPH MODE [BARGRP]	2411	OFF, RIGHT , LEFT, MIDOUT, MID IN	Selects output for a bar graph display when used with an RD4000 Remote Display
WEIGHT GRAPH [WTGRPH]	2412	ON/ OFF	Enables graph to be used with weight when used with a RD4000 Remote Display.
BAR WEIGHT [BAR WT]	2413	12000	Enter the full scale gross weight for the bar graph display.
PRESET GRAPH [PRGRPH]	2414	ON/ OFF	Enables graph to be used with presets when used with an RD4000 Remote Display.
TIMER GRAPH [TAGRPH]	2415	ON/ OFF	Enables graph to be used with timers when used with an RD4000 Remote Display.
NON DIGI-STAR DISPLAY [NONDSR]	2417	ON/ OFF	Enables non-DigiStar display mode
CAN MESSAGE TYPE [CANMSG]	2711	0 - 9	Allows entry of a proprietary CAN message type.
CAN MESSAGE INTERVAL [CANINT]	2712	0 , type value	Edit interval time for CAN message output.

SETTING [display]	D.A.N NO.	OPTIONS [displayed] BOLD=DEFAULT	DESCRIPTION
MENU 3 - MOTION & WEIGHT			
DISPLAY COUNT [COUNT]	3001	.01,.02,.05,.1,.2,.5,1,2,5,10 ,20, 50,100	Select display count size of weigh values.
CAPACITY [CAP]	3002	40,000	Enter MAXIMUM weight measurable on scale.
WM1 ADJUST 1 [WMA1-1]	3003	10 thru 19	Increase this number to smoothing weighing
WM1 ADJUST 2 [WMA1-2]	3004	0 thru 9, 4	0=off. Use value less than WMA1-1 for quick response weight.
WM1 ADJUST 3 [WMA1-3]	3005	4000	Enter the weight to active quick response weight Default-10% of scale capacity
WM2 ADJUST 1 [WMA2-1]	3006	30 thru 39	Increase this number to smoothing weighing
WM2 ADJUST 2 [WMA2-2]	3007	10 thru 19	10=off. Use value less than WMA2-1 for quick response weight.
WM2 ADJUST 3 [WMA2-3]	3008	4000	Enter the weight to active quick response weight Default-10% of scale capacity
MOTION [MOTION]	3101	ON/OFF	ON = Motion arrow flashes with unstable weight. Prevents: Print, Zero, Tare, Advance
MOTION WEIGHT [MOT WT]	3102	0	Enter weight used to detect motion. 0=Standard detection
MENU 4 - PRESET, ALARM, and TIMER			
PRE- ALARM METHOD [P MTHD]	4001	WEIGHT , PERCENT	Select weight or percentage method for pre-alarm
PRE-ALARM [P-ALM]	4002	50	Enter a value to activate an early warning that indicator is reaching the preset.
ALARM OUTPUT [AL OUT]	4003	OFF, PRESET , TR	Select preset or TR to control relay, horn & lamp.
BUZZER [BUZZER]	4004	OFF, ON , 1-10	ALARM BUZZER -allows user to turn off alarm horn when loading/unloading
RELAY [RELAY]	4005	OFF, PRESET, SETPNT, PRNOPA , SSPRST, PREACT, SEEDTD	Selects the behavior of the +12VDC alarm output; SEEDTD for stand controls, PRNOPA for variable throttle controls
PRESET DELAY [PRTDLY]	4006	0 thru 9	Set time to automatically advance/print entered preset
MANUAL RELAY OUT [RLYOUT]	4008	SIG12V , SIG 0V	Selects the state of the relay when the preset is reached.
PRESET CLEAR ON PRINT [PRCLPT]	4009	ON/OFF	Clears preset and preset ID when a print occurs
WEIGHT TOGGLE [WEITOG]	4012	ON/OFF	Name will toggle if no motion detected for 6 seconds.

SETTING [display]	D.A.N NO.	OPTIONS [displayed] BOLD=DEFAULT	DESCRIPTION
GROSS SET PNT OUTPUT <i>[SETOUT]</i>	4101	OVER/UNDER	Select when the +12VDC Alarm Output becomes active.
GROSS SET POINT CHNG <i>[SETCHG]</i>	4102	500	Set required weight change to turn off +12VDC Alarm Output.
GROSS SET POINT DELAY <i>[SETDEL]</i>	4103	0 thru 9	Set time delay before the +12VDC Alarm Output can Turn On/Off.
GROSS SET POINT <i>[SETPNT]</i>	4104	5000	Set a gross weight in long form that will activate +12VDC Alarm Output on Power cord.
SET POINT COUNT <i>[SETCTR]</i>	4105	0 thru 9	Counts how many times set point is activated.
SET POINT WEIGHT SOURCE <i>[STWTSC]</i>	4106	SERIAL/NORMAL	Sets weight source for use with set point feature.
TOLERANCE METHOD <i>[T MTHD]</i>	4201	WEIGHT, PERCENT	Select weight or percentage method for preset tolerance
TOLERANCE <i>[TOLER]</i>	4202	0 thru 9	Select tolerance weight percentage to accept preset.
TOLERANCE OVERLOCK <i>[OVERLCK]</i>	4203	OFF/ON	Prevents auto-advancing if preset exceeds tolerance
MENU 5 - COM PORT SETUP			
REMOTE DISPLAY PORT <i>[RNDPRT]</i>	5001	OFF, COM1, COM2 , COM3, COM4	Sets serial remote display output
RADIO PORT <i>[RADPRT]</i>	5002	OFF, COM1, COM2, COM3 , COM4	Sets internal radio port
EXTERNAL RADIO PORT <i>[EXRPRT]</i>	5003	OFF, COM1, COM2 , COM3, COM4	Sets external radio port
PRINTER PORT <i>[PRPRT]</i>	5005	OFF, COM1, COM2 , COM3, COM4	Sets printer port
SCOREBOARD PORT <i>[SCPRT]</i>	5006	OFF, COM1 , COM2, COM3, COM4	Sets scoreboard port
OPSTAT PORT <i>[OPSTAT]</i>	5007	OFF, COM1 , COM2, COM3, COM4	Sets Opstat port
DDL PORT <i>[DDLPRT]</i>	5009	OFF, COM1, COM2 , COM3, COM4	Sets DDL port
20MA MIRROR PORT <i>[20MARR]</i>	5011	OFF, COM1 , COM2, COM3, COM4	Sets port for 20MA signal to mirror
GPS PORT <i>[GPSPT]</i>	5013	OFF, COM1, COM2, COM3, COM4	Sets GPS port
SCOREBOARD 2 PORT <i>[SC2PRT]</i>	5015	OFF, COM1, COM2 , COM3, COM4	Sets scoreboard 2 port
CAN PORT <i>[CANPRT]</i>	5111	0 thru 9	Sets CAN port
DEBUG PORT <i>[DBGPRT]</i>	5999	OFF , COM1, COM2, COM3, COM4	Sets debugger port

SETTING [display]	D.A.N NO.	OPTIONS [displayed] BOLD=DEFAULT	DESCRIPTION
MENU 6 – SEED TENDER			
UNLOAD WEIGHT DISPLAY <i>{UNWEED}</i>	6301	LOAD , GROSS, NET	NET = from 0, GROSS = display total weight, LOAD = unload from preset
AUTO LOAD PRESET <i>{ALP}</i>	6302	OFF, STORED	Loads stored preset when unloading begins
PRESET ACTIVE SIGNAL TIMEOUT <i>{PRST}</i>	6303	0.0 for standard control 4.0 for variable throttle	Time to continue preset active signal after preset is reached. Used for variable throttle controls as the time to throttle down from full throttle.
UNLOAD ALARM <i>{U-RLM}</i>	6304	OFF , 1 - 5	Alarm buzzer duration.
OUTPUT TOLERANCE METHOD <i>{OTMTHD}</i>	6305	WEIGHT , PERCNT	Selects method for output tolerance
OUTPUT TOLERANCE <i>{OTOLER}</i>	6306	20 , type in value	Output tolerance is the weight offset of commodity remaining in the auger/ conveyor chute while filling the planter/ spreader.
UNLOAD DELAY <i>{UDELAY}</i>	6308	2.0 , type in value	Delays print/ data record time after PRESET for more accurate unload data.
NUMBER OF BINS <i>{BINNUM}</i>	6601	1 thru 16, 2	Number of bins 1-16, 1 = BIN feature off
VARIABLE THROTTLE <i>{STTHRO}</i>	6613	OFF for standard control, ON for variable throttle control	Enables seed tender variable throttle control mode. Changes DAN settings 4005 and 1401. Works with DAN 6303 to control throttle down time.
MENU 8 – SETUP, CALIBRATION, AND MAINTENANCE			
SIGNON SETTING <i>{SIGNON}</i>	8001	OFF , ON	Enables continuous display of sign-on message
SIGNON MESSAGE <i>{SIGMSG}</i>	8002	DIGI-S, TAR___	Enables editing of the sign-on message; up to 120 characters, 6 characters per screen
MAINTENANCE MESSAGE <i>{MAINTMG}</i>	8011	SEE OP, ERATOR, S MANU, AL FOR, _SERVI, CE INT, ERVAL_, REQUIR, EMENTS	Enables editing of the maintenance message; up to 120 characters, 6 characters per screen
MAINTENANCE MESS. TIME <i>{MAINTTM}</i>	8012	Time is entered using key pad.	Time for maintenance message to be triggered.
DEAD WEIGHT CAL <i>{WT CAL}</i>	8121	Follow instructions shown on LCD	Calibration method using weights
TEMPERATURE CALIBRATION <i>{T CAL}</i>	8123	OFF/ ON	On=Scale adjusts for temperature changes
INDICATOR SETUP INFO <i>{IS (SER)}</i>	8299		Sends all setup information to the serial port
KEYTEST	8888		Enables front panel key test

SETUP & CALIBRATION

SETUP NUMBER <i>[SETUP]</i>	8711	146040	Quick entry method selects weigh method 1-4 lbs, 5-8 kg, gain 1-9, display counts 1-9 and capacity *1000
Calibration Number <i>[CAL]</i>	8712	32640	Weight displayed at 0.4mV/V

15.0 INSTALLATION

15.1 Indicator Mounting

For most applications the equipment manufacturer provides the necessary mounting system and hardware, and mounts the Indicator for the End User.

Digi-Star provides a number of mounting options that allow the end user to customize the location and placement of the Indicator. The following section provides a list of the optional mounts.

In all cases the Digi-Star Indicator must be securely mounted to the equipment. Loose, or unsupported, Indicators can be damaged.

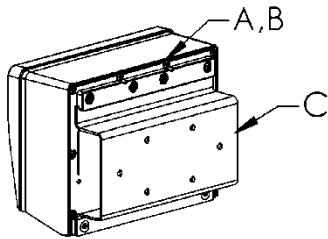

**STD UNIVERSAL
MOUNT TALL**

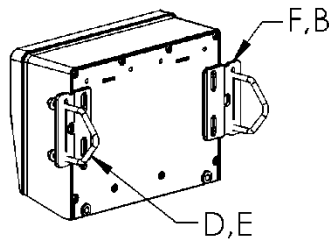

WING MOUNT

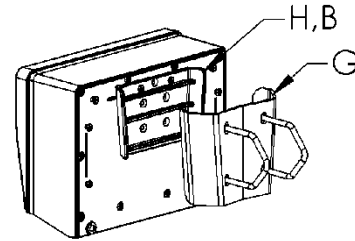

WEDGE MOUNT

KEY	PART NUMBER	DESCRIPTION
A	404353	BRACKET-EZ3 PLASTIC RAIL *
B	403780	SCR-#10 X 5/8 FHSTS BLACK ZP
C	840459	SUPPORT-HAT BRACKET
D	405069	U-BOLT 1/4-20 X 3.25 ZP
E	405084	NUT-1/4-20 TOP LOCKING FLANGE
F	403770	BRACKET- WING MOUNT *
G	405124	PACK-WEDGE MOUNT BRACKET WITH U-BOLTS & FLANGE NUTS
H	405244	EZ3 WEDGE MOUNT

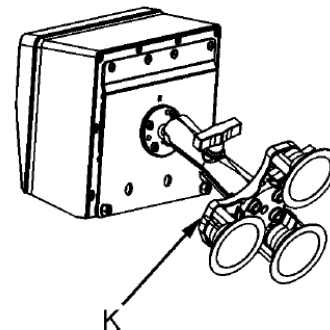
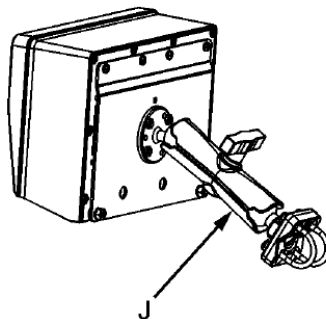
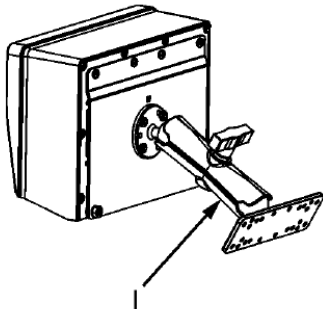

RAM MOUNTS

KEY	PART NUMBER	DESCRIPTION
I	404799	KIT-1.5" RAM MOUNT WITH BOLT-ON BASE WITH HARDWARE
J	407544	KIT-1.5" RAM MOUNT WITH DUAL U-BOLTS (FITS 0.5"-1.5" ROUND)
K	407434	KIT-1.5" RAM MOUNT WITH TRIPLE SUCTION CUP BASE

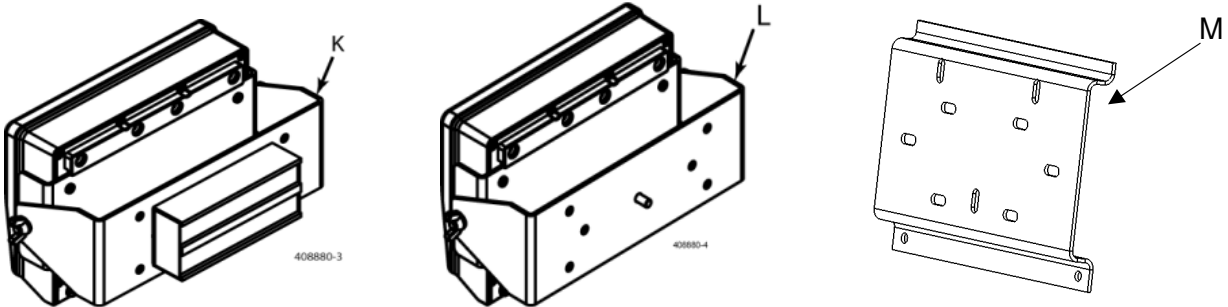

SIDE AND UNIVERSAL MOUNTS

KEY	PART NUMBER	DESCRIPTION
K	408880	MOUNT FOR LARGE INDICATORS WITH HARDWARE AND MAGNET
L	408828	MOUNT FOR LARGE INDICATORS WITH HARDWARE WITHOUT MAGNET
M	408199	UNIVERSAL MOUNT SHORT

15.2 Cable Connections

For accurate and reliable operation care should be taken when routing and connecting cables to the Digi-Star Indicator.

- Cables should be secured and protected from damage and abrasion.
- Long cables should not “hang” by the cable connector at the Indicator but should be secured to a structure close to the Indicator leaving a short “tail” to connect to the Indicator

Special Considerations for Power (+) and Ground (-):

- The Digi-Star Indicator is designed to operate at a continuous voltage ranging from 10.5 to 16.0 volts.
- Intermittent voltage drops to as low as 9.0 volts, such as when starting an engine, will be tolerated. Continuous low voltage will result in a Low Voltage warning on the display or the Indicator will power off.
- Voltage spike above 16 volts will damage the Indicator. **Never weld or charge the battery** on the equipment that the Indicator is mounted to without disconnecting the Indicator power cord. Never operate an Indicator on equipment with an engine charging circuit when the battery has been removed.
- Digi-Star recommends that the red power (+) and black ground (-) are connected as follows:
 - Power (+) can be either switched or keyed On & Off, or un-switched and always On.
 - Power (+) and Ground (-) should come from a dedicated auxiliary power source when provided. When auxiliary power sources are not provided power should come from the main power distribution system.
 - Fuse or circuit protection of at least 5 amps, but no more than 10 amps, should be provided. Although the Indicator is protected internally by an internal fuse a fuse or circuit protection is required to protect the power cable and equipment.
 - Ground (-) connection should be made to a main ground (the battery ground (-) is often connected to this location). **Do not use the chassis or frame of the equipment as a ground.**

A control box is required for proper connection to the ST3410. Improper wiring may damage the ST3410 or factory electronic controls such as the radio.

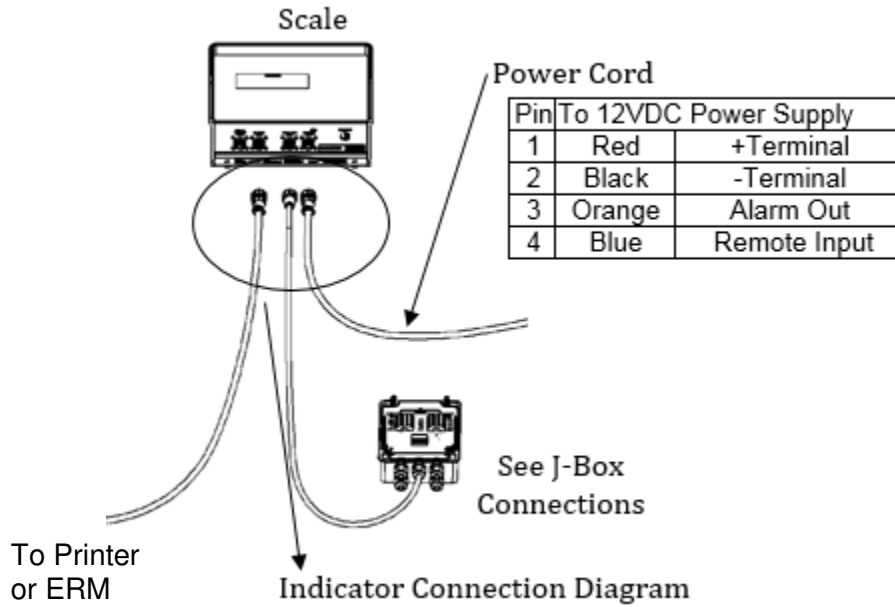

15.3 Auger Control Wiring

For standard ON/OFF, switch, or hydraulic type implement controls, refer to D3967 “408000 Control Box Installation” manual that arrived with your control box for wiring details.



For variable throttle implement controls, refer to D3977 “408221 and 408853 Control Box Installation” manual that arrived with your control box for details.



15.4 Connecting Load Cells to Junction Box

Connect load cell wires to terminal blocks. See wire color chart.

J-Box Illustrated for 4 Load Cells to be installed.

Wire Color Key		
	Color	Description
1	White	Signal +
2	Green	Signal -
3	Red	Excitation +
4	Black	Excitation -
5	Shield	Shield

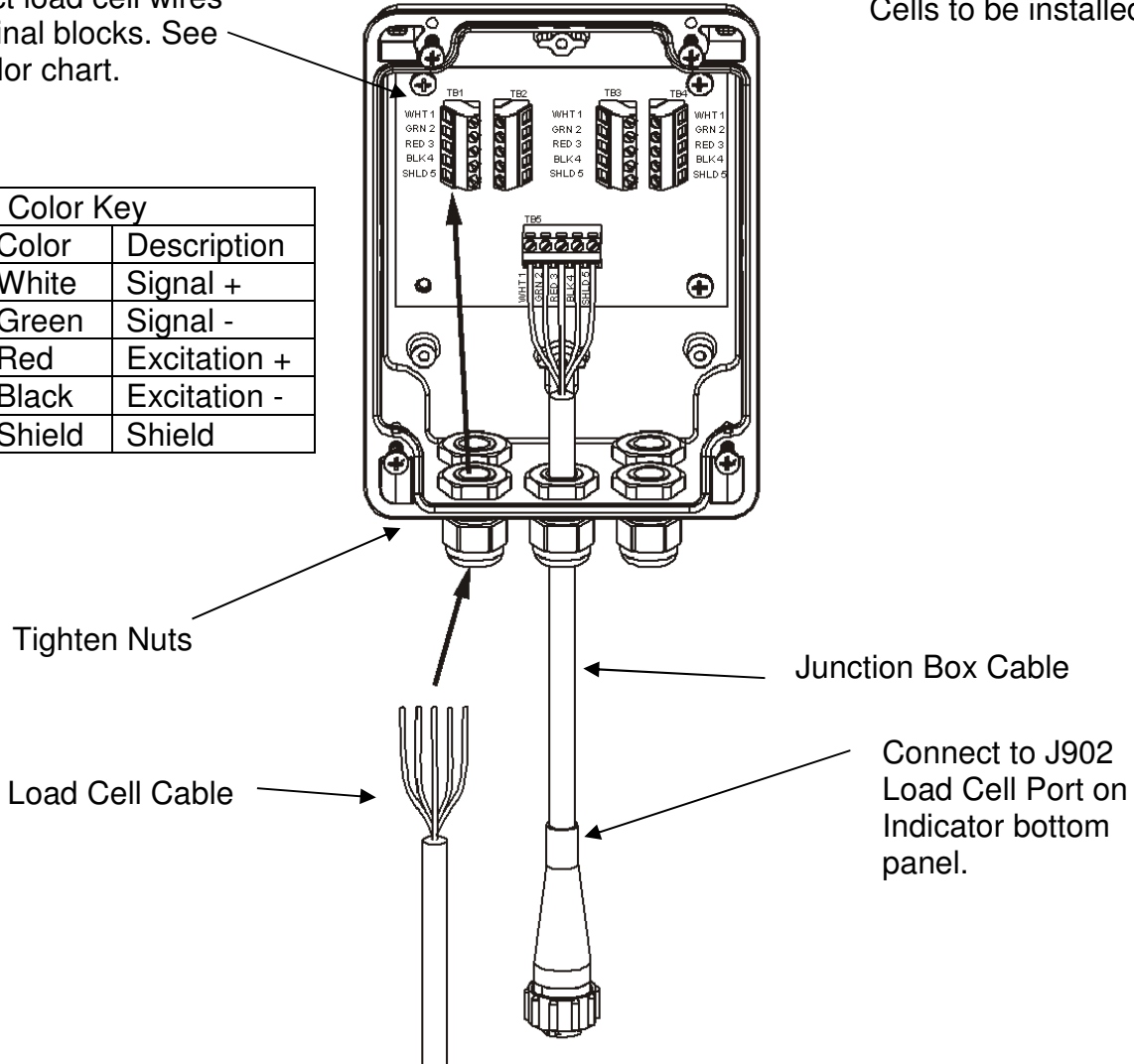

15.5 Load Cell Direction



Observe direction of arrow when installing load cell.

16.0 OPTIONAL EQUIPMENT

16.1 Bluetooth Module

Future

External Bluetooth Module – Future, IOS

16.2 IPC Thermal Printer



IPC Thermal Printer

Optional printer for RS232 serial port. Prints at every AUTO shut-off fill and button press.

16.3 Transmitter/Receiver



Transmitter (shown) with installed receiver inside ST3410 indicator. For ON/ OFF or switch type implement controls.

Use to activate auger/ conveyor from remote location. Operating range up to 90 feet.

Note: Option on standard ON/ OFF models only. Will not function on variable throttle models.

17.0 TROUBLESHOOTING FLOW CHART

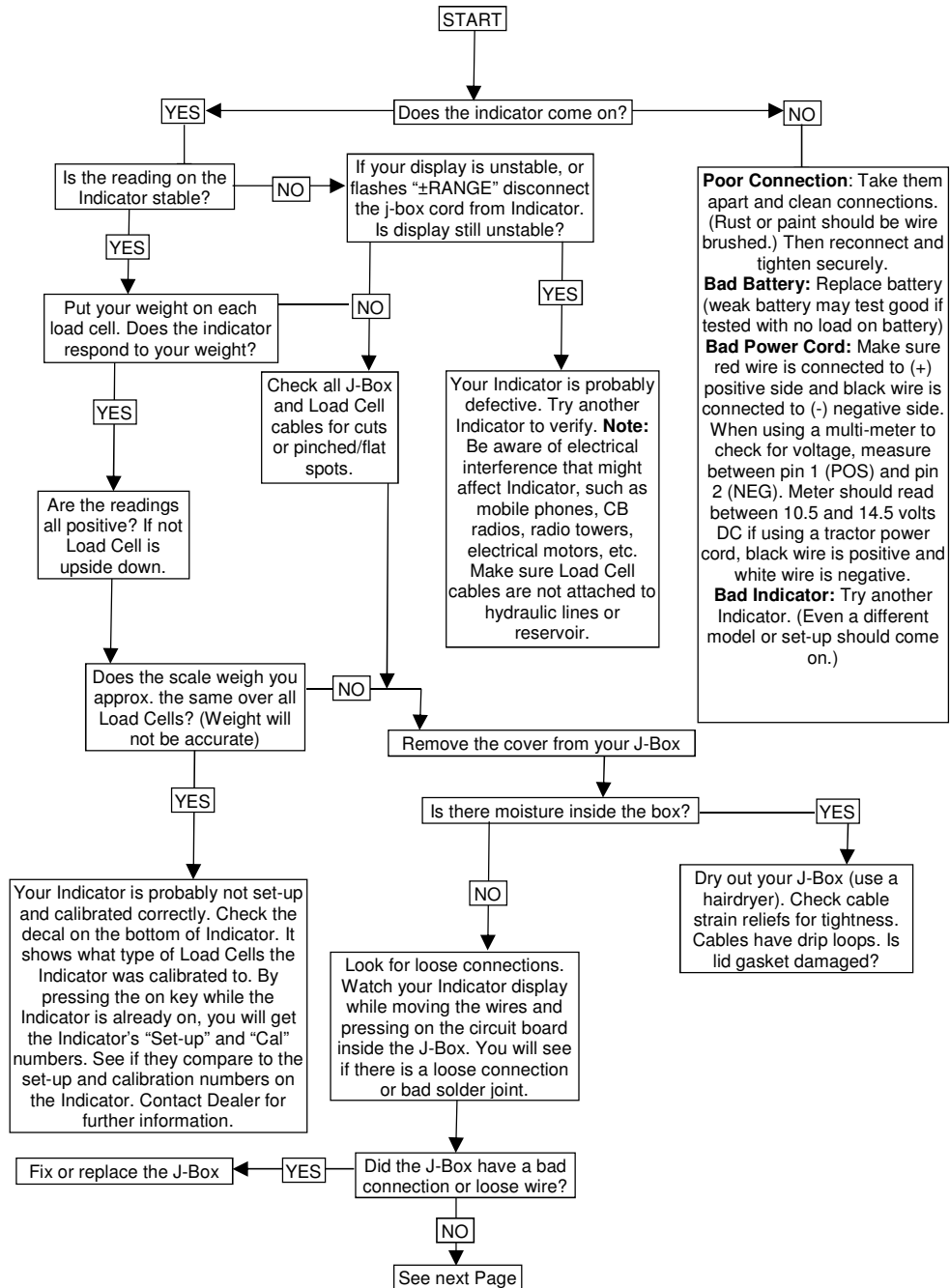

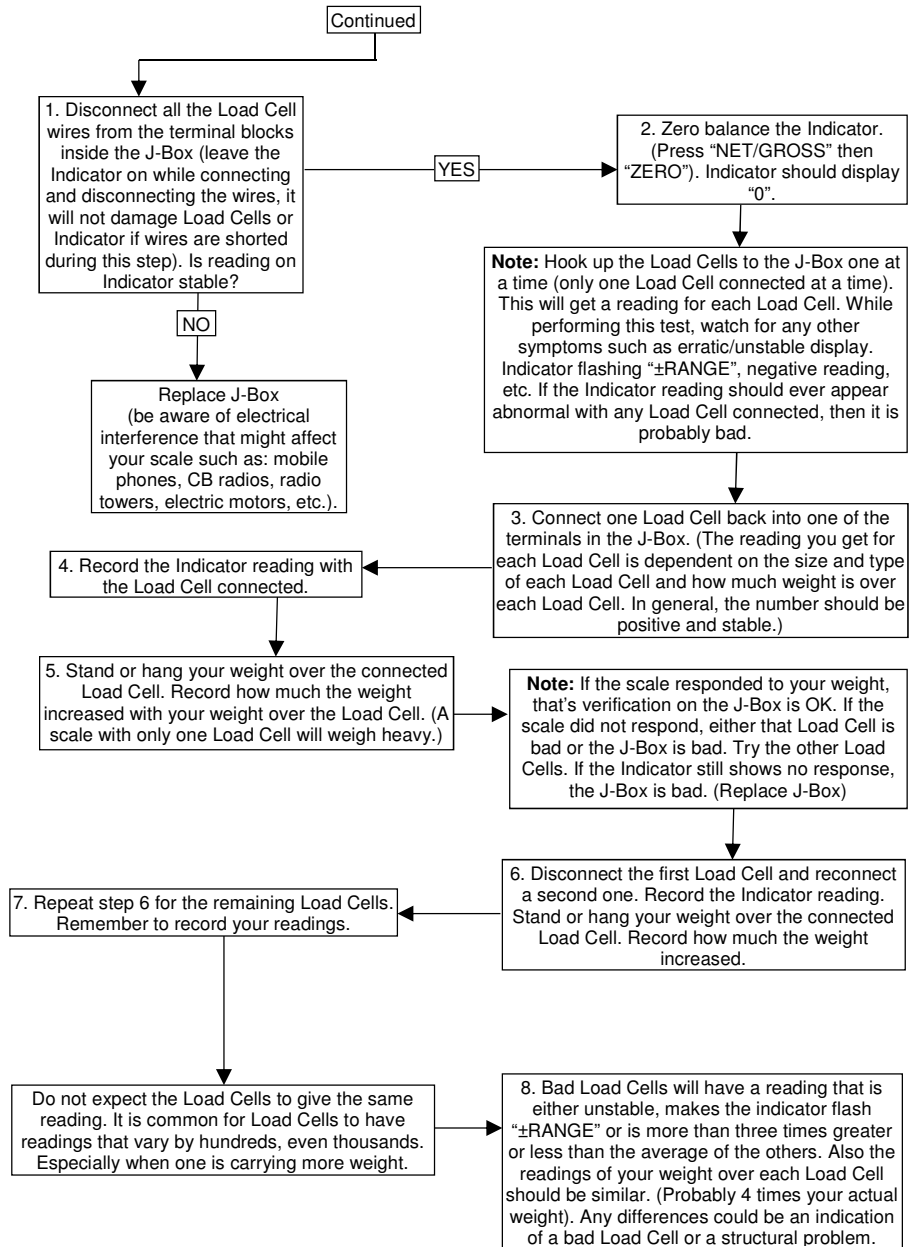

18.0 NOTES

SETUP NUMBER 8711 _____

CALIBRATION NUMBER 8712 _____

Pre-Alarm P-ALM 4001 _____

Output Tolerance OTOLER 6306 _____

Unload Delay UDELAY 6308 _____

PAST 6303 (Variable throttle time) _____

19.0 QUICK REFERENCE AID

QUICK REFERENCE

MANUAL – Manual Mode

1. Set control box switch to MANUAL.
2. Follow manufacturer's instructions to operate implement.

AUTO – Automatic Scale Mode

1. Set control box switch to AUTO.
2. Press BIN and Up/ Down arrows to select implement tank or hopper.
Remains in TOTAL when BIN function disabled.
3. Type PRESET weight with keypad, press ENTER to store.
4. Move chute to planter/ fertilizer.
5. Dispense commodity with factory control.
6. Auger/ conveyor will auto shutoff when reaching PRESET weight.
7. Repeat steps 4-6 to finish filling planter/ fertilizer.

Output Tolerance

Press 6306 SELECT to adjust Output Tolerance (OTOLER) when under or over filling the planter/ spreader. Press ENTER to store value. If dispensing too much commodity, increase OTOLER weight by amount of overfill. If not dispensing enough commodity, decrease OTOLER weight by amount of underfill.

Setting and Clearing BIN Weights

1. Press BIN and Up/ Down arrows, then ENTER to select BIN to update.
2. Press and hold ZERO to clear BIN weight.
3. Add weight to empty BIN, or;
4. Type known BIN weight on keypad.
5. Press BIN to store known weight. "BIN X STORED"

20.0 DECLARATION OF CONFORMITY

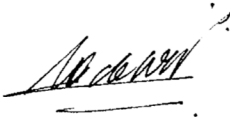
EMC DECLARATION OF CONFORMITY	
Application of Council Directive(s) <u>2004/108/EC</u>	
Manufacturer's Name:	Digi-Star, LLC
Manufacturer's Address:	W5527 State Hwy 106 Fort Atkinson, WI 53538
European Representative Name:	Digi-Star International
European Representative Address:	J.F. Kennedylaan 235 5981 WX Panningen The Netherlands
Model Name:	TMR3610, EZ3410, EZ2810
Conformance to:	§ EN 61326-1 electrical equipment for measurement, control, and laboratory use (See Report Number 314363.) § EN 55011, for Class B ISM equipment for industrial, scientific, and medical equipment. (See Report Number 314363.)
Equipment Type/Environment:	Electronic weighing scale systems; not legal for trade. For agricultural, commercial and industrial use.
Beginning Serial No.:	00001001
Year of Manufacture:	2015
We, the undersigned, hereby declare that the equipment specified above conforms to the above Directive(s).	
Manufacturer	Legal Representative in Europe
	
Signature	Signature
Full Name: Steven Gorseth	Full Name: Wim de Wit
Position: Director of Engineering	Position: Managing Director
Place: Fort Atkinson, WI U.S.A.	Place: Panningen, The Netherlands
Date: March 24, 2015	Date: March 24, 2015