

DIGI★STAR

P R E C I S E L Y

EZ2810



Operators Manual

DIGI★STAR

Ft. Atkinson, Wisconsin USA

DIGI★STAR

Panningen, the Netherlands

www.digi-star.com

Thank you for your purchase of a Digi-Star EZ2810 scale indicator. Your EZ2810 is the culmination of more than 30 years of agricultural weighing engineering and expertise. With proper operation and preventative maintenance the EZ2810 will last for many years.

The Digi-Star EZ2810 is primarily designed for weighing agricultural animal feed products during the loading and unloading of mobile and stationary feed mixers. The EZ2810 can also be used on feed delivery boxes, forage wagons, grain carts, and animal scales.

The EZ2810 is not for use with applications for which the EZ2810 is not intended, or as outlined in this manual.

Use of the EZ2810 outside of its intended purposes may result in inaccurate weight measurement or damage to instrument.

All rights reserved. Reproduction of any part of this manual in any form whatsoever without Digi-Star's express written permission is forbidden. The contents of this manual are subject to change without notice. All efforts have been made to assure the accuracy of the contents of this manual. However, should any errors be detected, Digi-Star would greatly appreciate being informed of these errors. The above notwithstanding, Digi-Star can assume no responsibility for errors in this manual or their consequence.

© Copyright! 2015 Digi-Star, Fort Atkinson (U.S.A.).

TABLE OF CONTENTS

SECTION 0 – PRODUCT OVERVIEW	5
0.1.0 Important: Record of Setup & Calibration Numbers.....	5
0.2.0 EZ2810 Special Features.....	6
0.3.0 Accuracy Statement	7
0.4.0 Technical Specifications.....	8
0.5.0 Safety During Use	9
0.6.0 Battery Charging and Welding	10
Section 1 - OPERATION	11
1.1.0 Indicator Overview.....	11
1.2.0 Turn ON Indicator.....	13
1.3.0 Zero Balance Indicator	13
1.4.0 Tare and Net/Gross.....	13
1.5.0 Print Key.....	15
1.6.0 Mixer Timer.....	15
1.7.0 Restart Mix Timer	15
1.8.0 Function & Select Keys	16
1.9.0 Memory Options M+, RM, MS, CM	16
1.9.1 Printing Weight from Memory.....	18
1.9.2 Weight Averaging	19
1.9.3 Printing Average Weight.....	20
1.9.4 Memory Store	20
1.9.5 Clear Memory.....	20
SECTION 2 — ADVANCE COMMANDS	21
2.1.0 Hold mode	21
2.2.0 Preset	21
2.3.0 Clear Preset	21
2.4.0 Preset Load	22
2.5.0 Load/Unload Mode	22
2.6.0 Net Mode	22
2.7.0 Preload a Tare.....	23
2.8.0 Pre-Alarm	23
2.9.0 Tolerance.....	24
2.9.1 Preset Delay Time.....	24
2.9.2 Rotation Counter	25
2.9.3 Re-Start Rotation Counter.....	25
2.9.4 Setting Drive Ratio	26
2.9.5 Maintenance message	27
2.9.6 Hour Meter.....	28
SECTION 3 - MENUS	29

3.1.0 Access to Menus.....	29
SECTION 4—SETUP / CALIBRATION	30
4.1.0 Viewing and Changing Setup & Calibration Numbers	30
4.1.1 Setup Number	30
4.1.2 Calibration Number	30
SECTION 5 — DIRECT ACCESS NUMBERS (DAN #'s)	31
5.1.0 Options Changed By User	31
SECTION 6 — INSTALLATION.....	41
6.1.0 Indicator Mounting	41
6.2.0 Cable Connections.....	43
6.3.0 Connecting Load Cells to Junction Box	44
6.4.0 Load Cell Direction.....	45
SECTION 7 - Optional Equipment	46
7.1.0 Cab Controls (Wireless).....	46
7.2.0 Remote Displays.....	46
7.3.0 Transmitter/Receiver.....	47
7.4.0 Printer Option.....	47
7.5.0 Data Transfer Options	47
7.5.0 Rotation Counter Sensor (Kit p/n: 408088)	48
SECTION 8 — Troubleshooting	49
8.1.0 Flow Chart.....	49
SECTION 9 – Declarations & Certificates	51
9.1.0 Declaration of Conformity (EU)	51
9.2.0 Legal-for-Trade Certification	52

SECTION 0 – PRODUCT OVERVIEW

0.1.0 Important: Record of Setup & Calibration Numbers

See Section 4 for how to access the Setup and Calibration numbers that were originally delivered with your Indicator and equipment, or note the correct or customized Setup and Calibration numbers here:

SETUP NUMBER: _____

CALIBRATION NUMBER: _____

0.2.0 EZ2810 Special Features

Preset Weight

The EZ2810 indicator provides simple to use and very useful Preset Weight feature. Using the numeric keypad the operator can enter the desired weight of product that the operator wants to load or unload. Once loading or unloading begins the EZ2810 will count down to 0 (zero). As the weight approaches 0 the audio and visual alarms will begin to pulse with the frequency of the pulses increasing the closer the preset weight gets to 0. At 0 the alarm light and buzzer will sound continuously.

See section 2.2.0 for details.

Rotation Counter / Timer

The Rotation Counter / Timer provides the useful benefit of monitoring mix revolutions or mix time and a warning light, buzzer, or external signal will indicate when the desired mix revolutions or time has been achieved. For this the EZ2810 uses an optional Rotation Counter Sensor (See Option Equipment Section: 7.5.0) which is fitted to the drive line of the feed mixer. See section 2.9.2 for details.

Maintenance Message

The Maintenance Message is available with the Machine Hour Meter function noted above and provides the ability for the equipment manufacturer or equipment owner to utilize the EZ2810 to display a specific Service or Maintenance message after a predetermined period of operation similar to a Change Oil message in an automobile.

See section 2.9.5 for details.

Machine Hour Meter

The EZ2810 when fitted with the Rotation Counter Sensor can be configured to record hours of operation. The Machine Hour Meter can provide valuable information to aid the user in determining when maintenance and upkeep is required.

See section 2.9.6 for details.

0.3.0 Accuracy Statement

READ THIS SECTION BEFORE USING THE SCALE SYSTEM

Digi-Star Scale Systems are designed and manufactured to provide the greatest accuracy possible. However proper installation and use are required in order to obtain the highest level of accuracy.

When using the scale system the following must be considered in order to realize the best possible performance and accuracy.

- Load cells must be installed with the proper orientation. Most Digi-Star load cells have a label indicating either the “TOP” or bending direction of the load cell. Inspect load cells to determine if the load cells are installed correctly. Incorrect installation of load cells will result in inaccurate measurement.
- Load cells should not be subjected to any strains or loads other than the weight of the load. Stress or strain caused by misalignment or other factors when accurate weight readings are desired will negatively affect the accuracy.
- The weighing unit should be stationary with minimum movement, and on a level surface, to insure that weight readings are as accurate as possible.
 - The effect of movement on accuracy depends on the speed and roughness of the ground and application. Rougher terrain and faster and/or greater movement increases the degradation of accuracy.
 - A level surface is defined as being less than a 5” (13cm) change in rise over 10’ (3.0m) of run. As the slope of the terrain increases, degradation of accuracy will also increase.

0.4.0 Technical Specifications

SIZE	10.25" long x 8.0" high x 4" wide (260mm x 190mm x 105mm)
WEIGHT	4.5 lbs. (2.04 Kg)
HELP MESSAGES	Context sensitive help messages in 10 languages, Long messages are scrolled
LOAD CELL EXCITATION	8 volts D.C. Nominal, Capable of driving ten 350 Ohms transducers, Short circuit proof
AUTO TEMPERATURE COMPENSATION	Of internal circuitry for high accuracy weighing measurements
LOAD CELL SIGNAL	Compatible with Load Cells with greater than 0.25 mv/v
CONNECTORS	AMP plastic weather resistant circular connector. Gold plated contacts.
POWER REQUIREMENTS	10.5 to 16.0 V.D.C. 160 mA nominal with four 350Ω L.C.
SET UP AND CALIBRATION	Via front panel or USB (???)
GROSS RANGE	999,999 max.display
LOW BATTERY WARNING	Enabled at 10.5V nominal
POUND/KILOGRAM	Selectable
DISPLAY	6 Digit Chip On Glass LCD 1.7" high
DISPLAY RESOLUTION	.01, .02, .05, .1, .2, .5, 1, 2, 5, 10, 20, 50, 100
DISPLAY UPDATE RATE	Selectable: 1, 2, 3, 4 times/sec.
MAX. DISPLAY RESOLUTION	Adjustable to 40,000 counts max.
ZERO TRACKING	Selectable, On/Off
SPAN ACCURACY	±(.1% + .005%/ °F) or (.1% + 0.009% °C) full scale ± 1 output count
MOTION DETECTION	Selectable, On/Off
ZERO ACCURACY	(.005%/ °F) or (0.009% °C) full scale ±1 output count for 0.5 mv/v transducer
ENVIRONMENTAL ENCLOSURE	IP65, IEC 529
WEIGH ALGORITHM	3 internally selectable digital filters to optimize performance (General, Slow, and Fast)
HOLD MODE	Used in mobile applications to stabilize displayed weight while moving the scale
NON-VOLATILE MEMORY	Standard
OPERATING TEMP	-29°C to 60°C -20°F to 140°F
2 REMOTE INPUTS (Power/Remote ports)	Tare / Print / Hold / Net Gross / M+ / Zero / TR Hold / Re-enter Preset / Switch
REMOTE PORT Power Output	2 x Large Display LED Remote Displays (RD4000) or 3 x Standard Display Remote Displays (RD2500V)

0.5.0 Safety During Use



Danger: Indicates an imminently hazardous situation that, if not avoided, could result in death or very serious injury.



Warning: Indicates a potential hazardous situation that, if not avoided, may result in death or very serious injury.



Caution: Indicates a potential hazardous situation that, if not avoided, may result in a minor injury.

Exposure to Radio Frequency

Exposure to energy from radio frequencies is an important safety issue. As this product uses the WiFi and Cellular system of a smartphone or tables please consult with the safety information provided with the device that the App operates with.

Prior to Operation

Read and understand this manual and learn all controls before you use the equipment.

Check that the area is clear of people, animals, and obstacles before starting any work.

Identify possible hazards.

Check system before use

Before using the App with the Digi-Star weighing system read the Operator's Manual for the scale indicator and the WiFi system. Follow all instructions.

Digi-Star cannot be held responsible for deviations and problems arising from incorrect use of the scale indicator, incorrect calibration, or settings. Furthermore Digi-Star cannot be held responsible for deviations and problems arising from technical problems to the system.



CAUTION!

Cleaning:

Do not use pressurized running water (high pressure cleaners, hoses nozzles, etc.) to clean the indicator.

Water ingress and damage to the indicator may result. Use soapy water and a sponge or cloth for best results.

0.6.0 Battery Charging and Welding

Disconnect all cables from the scale indicator as noted in diagram below before charging the battery or welding on the machine.

If cables are left connected, the scale indicator, optional devices and connected load cells could be damaged.





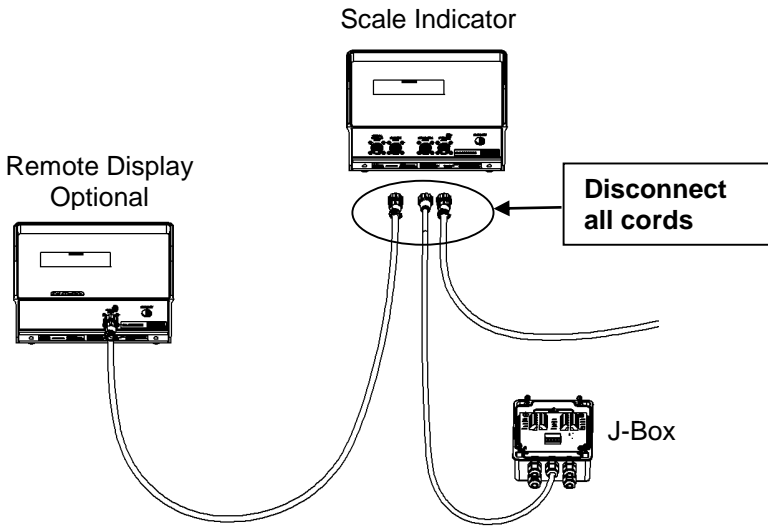



CAUTION!

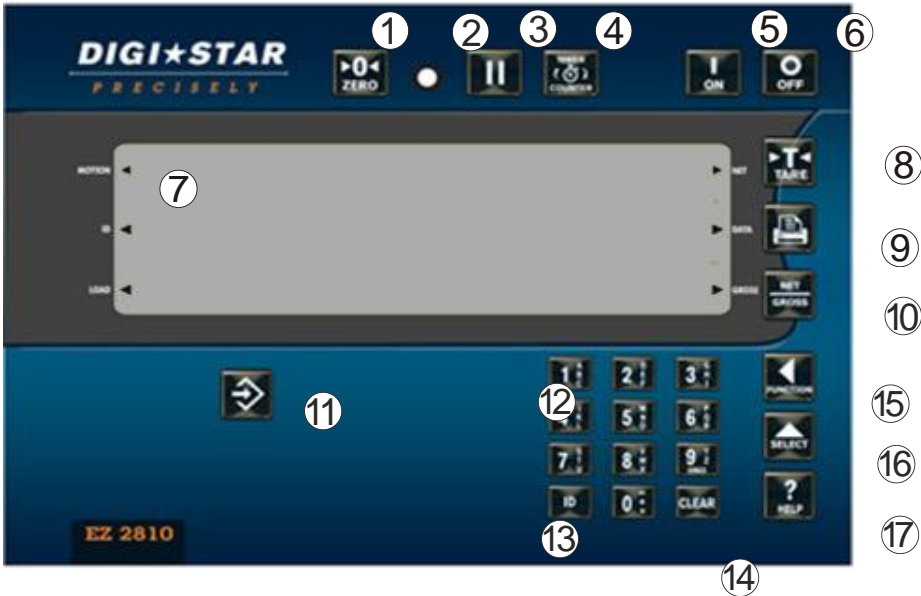









Section 1 - OPERATION

1.1.0 Indicator Overview



- ①  – Press and hold for 3 seconds to zero balance.
- ② **Pre-Alarm Light** – Flashes and Alarm sounds when weight at preset limit.
- ③  – Holds displayed weight when moving machine.
- ④  – Mixing time runs down, alarm sounds.
- ⑤  – Turns indicator on. Pressing while on will run self-test.
- ⑥  – Turns indicator off.
- ⑦ **Display Window** – Displays current actions.
- ⑧  – Temporary zero (Net mode).

- ⑨  – Records to memory or prints displayed weight.
- ⑩  – Toggles between Net and Gross weights.
- ⑪  – Accepts preset entry and menu changes.
- ⑫ **Keypad** – Input numbers or letters as required.
- ⑬  – To enter label number for weight value to be displayed and printed.
- ⑭  – Clear current command.
- ⑮  – Performs tasks displayed by select.
- ⑯  – Displays additional tasks.
- ⑰  – Shows additional information for last key pressed.

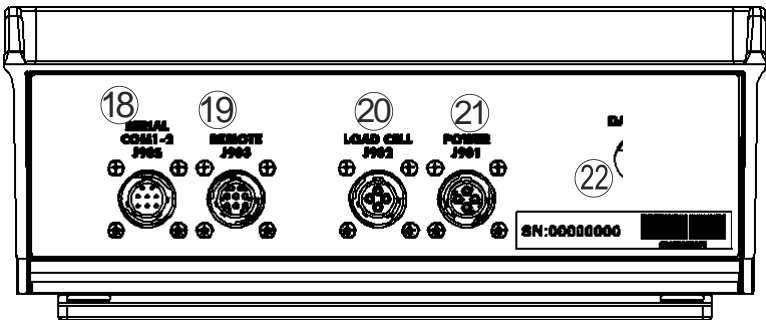

- ⑱ **Serial/Printer Port** – Option port for connection with other devices.
- ⑲ **Remote Port** – Optional remote display.
- ⑳ **Load Cell Port** – For J-Box cord.
- ㉑ **Power Port** – For power cord.
- ㉒ **Serial Number Plate** – Serial Number of indicator

1.2.0 Turn ON Indicator



1. Press



1.3.0 Zero Balance Indicator



1. Press and hold for 3 seconds to zero balance indicator



1.4.0 Tare and Net/Gross



2. Flashing arrow points to gross next to the display window, indicator ready to weigh.
3. Weight displayed, press sets zero weight.
4. Tare is a temporary zero (Net Weight) to display total weight (Gross Weight) Press





Pressing  displays zero weight and flashing arrow on side of display points to NET.



Add more weight.



To know total of original weight of 4000 pounds plus added 300 pounds, press  to show 4300 pounds, flashing arrow points GROSS.



Press  300 pounds displayed flashing arrow points NET.

1.5.0 Print Key

Note: Optional Serial port must be installed for printing.



1. Press . Indicator sends data to printer or PC.

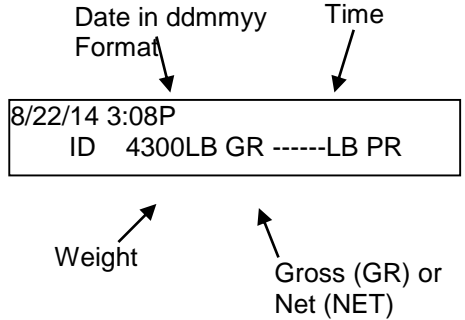

1.6.0 Mixer Timer

Stopwatch for mixing time.



1. Press .
2. Enter time, press . Time runs down, alarm sound and timer shows negative for over mixing of set time.
3. Press .

1.7.0 Restart Mix Timer



1. Press  twice without entering value starts timer using previously time

1.8.0 Function & Select Keys



1. Repeatedly press  gives following options:

M+: Adding weigh to weight memory

RM: Recall weight memory

CM: Clear weight memory

MS: Stores display weight to memory

Dimmer: Dimming backlight

Menu: View menus 1,2,3,4 and calibrate. See page 31.

Setup: Change setup and calibration numbers.

2. Once desired option is

displayed, press  to activate the option.

1.9.0 Memory Options M+, RM, MS, CM

Use these options to weigh truck or wagon one axle at a time. See the bottom page of 15 for more information.

M+



1. Add weight on scale. Example: 500 pounds.



2. Repeatedly press  until *M+* is displayed. Allow display to return to weight reading.

Now  is set to perform the *M+* option.



3. Press . *M+* will briefly be displayed, followed by *RM 500*. This will add 500 lbs. to indicator memory and return to gross weighing mode.





4. Put another weight on scale. Example: 1000 pounds.



5. Press . *M+* will briefly be displayed, followed by *RM 1500*. This will add another 1000 lbs. to indicator memory and return to gross weighing mode.



6. Repeatedly press  until *RM* is displayed.
7. Press  .
8. Total of both weights, 1500 pounds will be displayed, indicator switches to gross weight mode.



1.9.1 Printing Weight from Memory

Indicator must have optional serial/printer port for printing.



1. Repeatedly press  until *RM* displayed.



2. Press  shows weight in memory. Example: 1500 pounds.
3. Press  while weight displayed.

Sample output

```
8/22/14 3:08P
ID 1500LB RM -----LB PR
```

1.9.2 Weight Averaging



1. Repeatedly press  until *RM* displayed.



2. Press  twice within three seconds performs weight average.
3. Display shows *COUNT 2* if number of individual weights to average is two. Example weight of 1000 pounds and 500 pounds averaged.



4. Displays *AVERAG*.



5. Display shows average of two weights in memory. After displaying average weight, indicator returns to gross weight mode.

SECTION 2 — ADVANCE COMMANDS

2.1.0 Hold mode

Hold mode prevents displayed weight from changing while moving.



1. Press  holds displayed weight, indicator flashes weight and *HOLD*.

Press  returns indicator back to normal.

2. If weight added while in hold mode, press  cancels hold.

2.2.0 Preset

Enter amount to be loaded or unloaded, alarm sounds as zero is approached.



1. Enter desired preset weight.
2. Press  (Note: indicator rounds weight to nearest display count.)
3. Once preset entered, display shows weight loaded or unloaded in one of three display modes shown in Section 2.4.0.

2.3.0 Clear Preset



1. Press  to clear preset value.

2.4.0 Preset Load



1. Press .

As ingredients load or unload display counts up or down to preset value alternates between flashing word *PRESET* and amount, until 5 percent of weight is loaded or unloaded.

2.5.0 Load/Unload Mode



- Press .

Displays amount remaining to load or unload. As ingredients are loaded or unloaded, display counts down from entered weight to *ZERO*.

2.6.0 Net Mode





1. Press  twice.

Displays weight added since preset entered. As ingredients are loaded or unloaded, display counts up or down.

2.7.0 Preload a Tare

For weighing containers after loading to exclude the weight of the container. If weight of container is known, a Tare weight is preloaded in indicator and only the Net weight of the product is displayed.



- Enter 1103, then press  to access Pre-Tare.
- Press  to enable the option.
- Press  to return to weighing mode.

1. Press and hold  for 3 seconds to zero balance the indicator.

2. Add weight to container.

3. Enter known weight of unloaded container.

4. Press .

5. Press .

2.8.0 Pre-Alarm

“Early Warning” for preset. Pre-alarm activates at weight or percentage of preset value.



1. Enter 4001 press .

2. Repeatedly press  choose weight or percent.

3. Press .

4. Enter number to activate pre-alarm.



5. Press  stores setting.

2.9.0 Tolerance

% ingredient can be under/over-loaded and still automatically advance



Enter **4201** press .

1. Repeatedly press  displays tolerance amount by percentage.
2. Press  stores setting.
3. Enter number for tolerance setting.
4. Press  stores setting.

Note: OFF setting always advances after ingredient amount reached, if delay timer is set.

2.9.1 Preset Delay Time

Time indicator waits before automatically advancing/printing entered preset weight.



Enter **4006** press .

1. Using keypad, enter number (in seconds) before automatic advance/printing. (See note)
2. Press  stores setting.







Note: 0 setting prevents auto-advance.

2.9.2 Rotation Counter

Indicator counts mixer auger rotations. Allows user to know how long feed has mixed.



Note: Feature requires optional rotation sensor kit.

1. Enter **4301** press .
2. Press  to pick REV option.
3. Press .
4. Press .
5. Enter number of rotations.
6. Press  rotation counter counts down. Counter reaches zero, alarm light and buzzer on.
7. Press .

2.9.3 Re-Start Rotation Counter



1. Press  twice starts rotation counter using previous count.

2.9.4 Setting Drive Ratio

Drive ratio is number of turns seen by sensor divided by number of mixing rotations.



1. Enter 4302 press  .



2. Enter drive ratio.

3. Press  .

2.9.5 Maintenance message

Message can be used to alert the user of maintenance needed to be done on the equipment.

Rotation Counter Sensor Kit (p/n: 408088) required for this feature.

For proper maintenance schedule, refer to your OEM equipment's operator's manual.



1. Enter **8011** using key pad, then press “SELECT”. The user may edit the maintenance message using key pad.



2. “MANTMG 1”, then edit maintenance message using key pad. Key pad “1” does; Example 1-A-B-C. Key pad “2” does; Example 2-D-E-F. When finished, press “ENTER”. Example messages; “GREASE PTO SHAFT”. Example; “CHANGE ENGINE OIL”.

There are 10 MANTMG windows to enter user’s message. Six letters, spaces or numbers fit in one maintenance message window. The maintenance message scrolls as one message.

2.9.6 Hour Meter



1. Then enter **8012** using key pad, press SELECT.

2. Enter number of hours for maintenance message to be triggered using key pad, then press ENTER. Example; 50 hours of equipment operation time, then maintenance message will be displayed on LCD.

User will need to acknowledge message by pressing “ON” key.

Message will be display on each power cycle and every 4 hours of operation until user enters new maintenance time.

User can enter new time using D.A.N. 8012.

SECTION 3 - MENUS

3.1.0 Access to Menus



1. Press and hold **NET GROSS** and **ON** .
2. Press **SELECT** for menus.
3. Press **→** to enter selected menu.



ONCE IN MENU:

4. Press **→** scrolls options.
5. Press **SELECT** changes options.
6. Press **→** saves changes.

SECTION 4—SETUP / CALIBRATION

4.1.0 Viewing and Changing Setup & Calibration Numbers

4.1.1 Setup Number



1. Enter **8711**, press  .
2. Indicator shows *SETUP* briefly then show a 6 digit number on LCD. This is the current Setup Number. Enter new number if required.

3. Press  .

4.1.2 Calibration Number









1. Enter **8712**, press  .
2. Indicator shows *SETUP* briefly then show a 6 digit number on LCD. This is the current Setup Number. Enter new number if required.

3. Press  .

SECTION 5 — DIRECT ACCESS NUMBERS (DAN #'s)

5.1.0 Options Changed By User

To display menus 1, 2, 3, 4, 5 and Calibrate:

1. Repeatedly press  until MENU is displayed.
2. Press and hold  .
3. Repeatedly press  to select Menu1, 2, 3, 4, 5 or calibrate.
4. Press  displays setting name and allows value changes.
5. Press  or  selects options for each setting/display.
6. Press  saves setting and next option for menu displays.

SETTING [display]	D.A.N NO.	OPTIONS [displayed] BOLD=DEFAULT	DESCRIPTION
MENU 1 - GENERAL SETTINGS			
LANGUAGE (LANGAG)	1001	English Dutch French German Italian Portuguese Spanish Danish Hungarian Spanish Polish	<i>(ENGLISH)</i> <i>(DUTCH)</i> <i>(FRANCE)</i> <i>(GERMAN)</i> <i>(ITALY)</i> <i>(PORT)</i> <i>(SPAN)</i> <i>(DANISH)</i> <i>(HUNG)</i> <i>(SPAN)</i> <i>(POLSK)</i>
DISPLAY RATE (DRATE)	1002	1,2,3,4,6,7,8,9,10	Update display times per second.
SCALE ID SETUP (SCALE ID)	1003	NEW EZ	Identity of scale location (truck id or Mixer number).
ZERO TRACK (ZTRACK)	1004	ON/OFF	If ON -zero track adjust balance for buildup of snow & mud.

SETTING [display]	D.A.N NO.	OPTIONS [display] BOLD=DEFAULT	DESCRIPTION
WEIGH METHOD [W MTHD]	1005	1=General 2=Fast 3=Slow	Select weigh method. The speed the weight changes as shown on the LCD.
1 PRESS ZERO [1 ZERO]	1006	ON/OFF	If ON -press and hold Zero key to Zero/Balance scale.
AUTO OFF [AUTOFF]	1007	OFF , 15, 30, 45, 60	Indicator turns off after selected minutes of stable weight.
DISPLAY UNIT [L B-KG]	1008	LB/KG	Display pounds – LB or Kilograms - KG
SCROLL DELAY [SCROLL]	1101	0,1,2,3,4, 5, 6, 7, 8, 9	Scroll rate for cold temperatures 0=normal 9=slowest
SAVE TARE [SAVTAR]	1102	ON/OFF	Saves tare weight to non-volatile memory.
PRELOAD TARE [PRETAR]	1103	ON/OFF	Tare weights can be entered using the numeric keypad.
TIME FORMAT [TIME F]	1201	24 HR AM/PM	Select time format -AM/PM or 24 hours
TIME [TIME]	1202	XX:XX:XX, AM/PM	Enter changes hh:mm:ss (use numeric keypad) use function key to change between hh:mm:ss. Then choose AM/PM.
DATE FORMAT [DATE F]	1203	1-mm-dd 2-mm/dd/yy 3-mm/dd/yyyy 4-dd-mm 5-dd/mm/yy 6-dd/mm/yyyy 7-ddmmyy 8-ddmmyyyy	Select date format
DATE [DATE]	1204	Enter ddmmyy	Select key changes date or numerical keys -function key chooses dd/mm/yy.
DATE CHECK [DT CHK]	1205	ON/OFF	Verifies the real time clock has a valid date at power up.
REMOTE INPUT 1 [RM INP 1]	1401	TARE , PRINT, HOLD, NETGRS, M+, ZERO,OFF, PRESET,	Sets function of remote input line on the power cord.

SETTING [display]	D.A.N NO.	OPTIONS [display] BOLD=DEFAULT	DESCRIPTION
		SWITCH	
REMOTE 1 SWITCH MESSAGE <i>[R1 MSG]</i>	1402	OPEN,-,-,+,-*,-0, -1,-2,- 3, -4,-5,-6,-7,-8,-9,-A,-B,- C, -D,-E,-F,-G,-H,-I,-J,-K,- L, -M,-N,-O,-P,-Q,-R,-S,- T,-U, -V,-W,-X,-Y,-Z	Message that is displayed for remote input condition. D.A.N. 1401 set to "switch".
REMOTE 1 SWITCH STATE <i>[R1 STAT]</i>	1403	OPEN/ CLOSED	Set remote input line state that displays message and/or illuminates alarm lamp. D.A.N. 1401 set to "switch".
REMOTE 1 SWITCH MESSAGE TIME <i>[R1 TIME]</i>	1404	1...2-9	Set how often the remote switch message is displayed. Once every 1-9 seconds. D.A.N. 1401 set to "switch".
REMOTE INPUT 2 <i>[RMINP2]</i>	1411	TARE , PRINT, HOLD, NETGRS, M+, ZERO, TR HLD, OFF, PRESET, SWITCH	Sets function of remote input line on the remote port.
REMOTE 2 SWITCH MESSAGE <i>[R2 MSG]</i>	1412	OPEN	Message that is displayed for remote input condition. D.A.N. 1411 set to "switch".
REMOTE 2 SWITCH STATE <i>[R2 STAT]</i>	1413	OPEN/ CLOSED	Set remote input line state that displays message and/or illuminates alarm lamp. D.A.N. 1411 set to "switch".
REMOTE 2 SWITCH MESSAGE TIME <i>[R2 TIME]</i>	1414	0...2-9	Set how often the remote switch message is displayed. Once every 1-9 seconds. D.A.N. 1411 set to "switch".
PROGRAM ID <i>[PRG I ID]</i>	1998		Displays current software version
ESTIMATED WEIGHT <i>[EST WT]</i>	1999	Enter weight value using key pad. Then press enter.	Manually adjust Gross weight of scale by changing zero/balance. Press "on" to continue.

MENU 2 - COMMUNICATIONS FEATURES

SETTING [display]	D.A.N NO.	OPTIONS [display] BOLD=DEFAULT	DESCRIPTION
REMOTE [REMOTE]	2001	ON/OFF	If ON indicator communicates with Cab Control Display
SCALE NUMBER [SCL NO]	2002	1,2,3,4,5,6,7,8,9,10,11,12, 13,14,15,16,17,18,19,20, 21,22,23,24	Select scale number for cab control communication
EXTERNAL RADIO [EXTRAID]	2003	ON/OFF	Enables external radio to be connected to the J905 port.
DDL ATTACHED [DDL]	2004	YES/NO	Enables connection of a DDL (Data DownLoader)
SCOREBOARD MODE [SCOREM]	2101	0,1,2,3,4,5,6,7,8,11,12, 15,27,37,38,39	Select scoreboard output
ZERO OUTPUT [ZEROUT]	2102		Allows zero/balance for SCOREM #11 serial gross weight.
FRONT PANEL ZEROUT [ZEROFF]	2103	OFF/ON	Allows use of the zero key to zero/balance the serial gross weight.
OPERATION STATUS [OPSTAT]	2111	0, 2	Select operating data to be sent to a Remote Terminal
COM 1 BAUD RATE [C1 BDD]	2201	1200,2400, 4800, 9600 , 14400, 19200, 38400, 57600, 115200	Sets baud rate for com port #1
COM 1 PARITY [C1 PPA]	2202	NONE, ODD, EVEN	Sets parity for com port #1
COM 1 DATA BITS [C1 DATA]	2203	7, 8	Sets data bits for com port #1
COM 1 DELAY [C1 DL:]	2204	0, .10, .25, .50, .75, 1-5	Selects seconds to delay before advancing to next line.
COM 2 BAUD RATE [C2 BDD]	2211	1200,2400, 4800, 9600 , 14400, 19200, 38400, 57600, 115200	Sets baud rate for com port #2
COM 2 PARITY [C2 PPA]	2212	NONE , ODD, EVEN	Sets parity for com port #2
COM 2 DATA BITS [C2 DATA]	2213	7, 8	Sets data bits for com port #2

SETTING [display]	D.A.N NO.	OPTIONS [display] BOLD=DEFAULT	DESCRIPTION
[[C2]DATA]			
COM 2 DELAY [[C2]DL:Y]	2214	0, .10, .25, .50, .75, 1-5	Selects seconds to delay before advancing to next line.
TARE AUTO PRINT [TAREAP]	2301	ON/OFF	If ON -tare auto-prints displayed weight.
ONE LINE PRINT [IL PRT]	2302	ON/OFF	If ON -indicator data prints on one line.
AUTO PRINT [APPRINT]	2303	ON/OFF	If ON -pressing keys auto-prints weight values.
PRINT FORMAT [PRTFMT]	2304	AUTO , WTONLY, DOWNLD, DT+TM, ID+TM, IDWTTM, BATCH1, PRTAC1, PRTAC2, PRTAC3, PRWTRC, WTRCTM,3200-A, 3200-B, SCLABC	Select alternate & comma (CSV) formats.
PRINT ACCUMULATION [PRTACC]	2305		Shows a running total of weights printed.
REMOTE DISPLAY [RM]DISP]	2401	EZ2 , EZ3MUX, COG,NONE	Select type of remote display
REMOTE TERMINAL [RMTERM]	2402	ON/OFF	Sends display data to serial remote terminal interface
BAR GRAPH MODE [BARGRP]	2411	OFF, RIGHT , LEFT, MIDOUT, MID IN	Selects output for a bar graph display when used with an RD4000 Remote Display
WEIGHT GRAPH [WTGRAPH]	2412	ON/OFF	Enables graph to be used with weight when used with a RD4000 Remote Display.
BAR WEIGHT [BAR WT]	2413	12000	Enter the full scale gross weight for the bar graph display.
PRESET GRAPH [PRGRPH]	2414	ON/OFF	Enables graph to be used with presets when used with an RD4000 Remote Display.
TIMER GRAPH	2415	ON/OFF	Enables graph to be used with timers when used with an

SETTING [display]	D.A.N NO.	OPTIONS [displayed] BOLD=DEFAULT	DESCRIPTION
[TMGRPH]			RD4000 Remote Display.
MENU 3 - MOTION & WEIGHT			
DISPLAY COUNT [[COUNT]	3001	.01,.02,.05,.1,.2,.5,1,2,5 10 ,20, 50,100	Select display count size of weigh values.
CAPACITY [[CAP]	3002	40,000	Enter MAXIMUM weight measurable on scale.
WM1 ADJUST 1 [WMA 1-1]	3003	10 thru 19	Increase this number to smoothing weighing
WM1 ADJUST 2 [WMA 1-2]	3004	0 thru 9	0=off. Use value less than WMA1-1 for quick response weight.
WM1 ADJUST 3 [WMA 1-3]	3005	4000	Enter the weight to active quick response weight Default-10% of scale capacity
WM2 ADJUST 1 [WMA2-1]	3006	30 thru 39	Increase this number to smoothing weighing
WM2 ADJUST 2 [WMA2-2]	3007	10 thru 19	10=off. Use value less than WMA2-1 for quick response weight.
WM2 ADJUST 3 [WMA2-3]	3008	4000	Enter the weight to active quick response weight Default-10% of scale capacity
MOTION [MOTION]	3101	ON/OFF	ON = Motion arrow flashes with unstable weight. Prevents: Print, Zero, Tare, Advance
MOTION WEIGHT [MOT WT]	3102	0	Enter weight used to detect motion. 0=Standard detection
MENU 4 - PRESET, ALARM, and TIMER			
PRE ALARM METHOD [P MTH]	4001	WEIGHT, PERCENT	Select weight or percentage method for pre-alarm
PRE-ALARM [P-ALM]	4002	100	Enter a value to activate an early warning that indicator is reaching the preset.
ALARM OUTPUT [AL OUT]	4003	OFF, PRESET , TR	Select preset or TR to control relay, horn & lamp.
BUZZER [BUZZER]	4004	OFF, ON , 1-10	ALARM BUZZER -allows user to turn off alarm horn when

SETTING [display]	D.A.N NO.	OPTIONS [display] BOLD=DEFAULT	DESCRIPTION
			loading/unloading
RELAY (RELAY)	4005	OFF, PRESET , SETPNT	Selects the behavior of the +12VDC alarm output
PRESET DELAY (PRT DEL)	4006	0 thru 9	Set time to automatically advance/print entered preset
GROSS SET PNT OUTPUT (SETOUT)	4101	OVER/UNDER	Select when the +12VDC Alarm Output becomes active.
GROSS SET POINT CHNG (SETCHG)	4102	500	Set required weight change to turn off +12VDC Alarm Output.
GROSS SET POINT DELAY (SETDEL)	4103	0 thru 9	Set time delay before the +12VDC Alarm Output can Turn On/Off.
GROSS SET POINT (SETPNT)	4104	5000	Set a gross weight in long form that will activate +12VDC Alarm Output on Power cord.
SET POINT COUNT (SETCTR)	4105	0 thru 9	Counts how many times set point is activated.
SET POINT WEIGHT SOURCE (SETWTS)	4106	SERIAL/ NORMAL	Sets weight source for use with set point feature.
TOLERANCE METHOD (T MTH)	4201	WEIGHT , PERCENT	Select weight or percentage method for preset tolerance
TOLERANCE (TOLER)	4202	0 thru 9	Select tolerance weight percentage to accept preset.
TOLERANCE OVERLOCK (OVERLK)	4203	OFF/ON	Prevents auto-advancing if preset exceeds tolerance
TIMER, COUNTER (TMRC TR)	4301	TIMER , COUNTER	Select time or mixer revolutions to decrement mix timer/counter.
DRIVE RATIO (DRATIO)	4302	0001.00	Enter the number of input pulses that equal 1 mixer revolution. REVCTR needs to be enabled in the setup options. D.A.N. 4301 set to COUNTER.
MENU 5 - COM PORT SETUP			
REMOTE	5001	OFF, COM1, COM2 ,	Sets serial remote display

SETTING [display]	D.A.N NO.	OPTIONS [displayed] BOLD=DEFAULT	DESCRIPTION
DISPLAY PORT <i>[RM]PRT</i>		COM3	output
RADIO PORT <i>[RA]PRT</i>	5002	OFF, COM1, COM2, COM3	Sets internal radio port
EXTERNAL RADIO PORT <i>[EX]RPRT</i>	5003	OFF, COM1, COM2 , COM3	Sets external radio port
PRINTER PORT <i>[PR]PRT</i>	5005	OFF, COM1, COM2 , COM3	Sets printer port
SCOREBOARD PORT <i>[SC]PRT</i>	5006	OFF, COM1 , COM2, COM3	Sets scoreboard port
OPSTAT PORT <i>[OP]STAT</i>	5007	OFF, COM1 , COM2, COM3	Sets opstat port
DDL PORT <i>[D]DL PRT</i>	5009	OFF, COM1 , COM2, COM3	Sets DDL port
20MA MIRROR PORT <i>[20]MAMP</i>	5011	OFF, COM1, COM2 , COM3	Sets port for 20MA signal to mirror
RECIPE PORT <i>[RE]CPRT</i>	5012	OFF, COM1, COM2 , COM3 invalid	Sets recipe output port
DEBUG PORT <i>[D]GPRT</i>	5999	OFF , COM1, COM2, COM3	Sets debugger port

SETUP FEATURES

SIGNON SETTING <i>[SI]GNON</i>	8001	OFF , ON	Enables continuous display of sign-on message
SIGNON MESSAGE <i>[SI]GMSG</i>	8002	SIGMSG 1,2,3	Enables editing of the sign-on message
MAINTENANCE MESSAGE <i>[MA]NTMG</i>	8011	MANTMG 1, 2, 3, 4, 5, 6, 7, 8, 9, 10, 11	Enables editing of the maintenance message
MAINTENANCE MESS. TIME <i>[MA]NTTM</i>	8012	Time is entered using key pad.	Time for maintenance message to be triggered.
DEAD WEIGHT	8121	Follow instructions	Calibration method using

SETTING [display]	D.A.N NO.	OPTIONS [displayed] BOLD=DEFAULT	DESCRIPTION
CAL [WT [CAL]]		shown on LCD	weights
TEMPERATURE CALIBRATION [T [CAL]]	8123	OFF/ON	On=Scale adjusts for temperature changes
INDICATOR SETUP INFO [DIS (SER)]	8299		Downloads all setup information to the serial port
KEYTEST	8888		Enables front panel key test
SETUP & CALIBRATION			
SETUP NUMBER [SETUP]	8711	146040	Quick entry method selects weigh method 1-4lbs, 5-8 kg, gain 1-9, display counts 1-9 and capacity *1000
Calibration Number [CAL]	8712	32640	Weight displayed at 0.4mV/V
SETTING (display)	D.A.N. NO.	OPTIONS (displayed) BOLD=DEFAULT	DESCRIPTION
PRESET OPTION ENABLED (PRESET)	90002	Enable/disable	Allows for entering a target NET weight.
RS232 OPTION ENABLE (RS-232)	90003	Enables/disable	Enables/disables serial port
A/D DISPLAY ENABLED (ADDISP)	90005	Enables/disable	Enables A/D counts in place of weight display.
HOLD OPTION ENABLED (HOLD)	90007	Enable/disable	Enables the HOLD key functionality
MEMORY OPTION ENABLED (MEMORY)	90008	Enable/disable	Enables/disables the M+, RM, CM options in the SELECT/FUNCTION key menu.

SETTING [display]	D.A.N NO.	OPTIONS [displayed] BOLD=DEFAULT	DESCRIPTION
BLACK-OUT OPTION ENABLED (BLKOUT)	90009	Enable/disable	Enables functionality to restore the indicator to its previous state before power loss.
TIMER OPTION ENABLED (TIMER)	90011	Enable/disable	Allows countdown timer to be set using the TIMER key.
INTERNAL RADIO ENABLED (RADIO)	90012	OFF / ON	Enables/disables radio—requires radio hardware
ROTATION COUNTER (REVCTR)	90016	OFF / ON	Enables/disables rotation counter
NUMBER KEYPAD ENABLED (NUMKEY)	90051	ON / OFF	If ON—Enables front panel number pad
QWERY KEYPAD ENABLED (QWERTY)	90061	ON / OFF	If ON—Enables QWERTY style keyboard
MODEL IDENTIFICATION (MODELID)	90201	EZ2810	Allow entry of specific model ID to be display at power up.
MODEL ID TIME (MODLTM)	90202	YES / NO	If ON---Entry amount of time for MODEL ID to be display at power up.
CLEAR PEAK WEIGHT (CLRPKW)	90302	YES / NO	If ON—Allows clearing of stored Peak weights
CLEAR ROTATION COUNTER (CLRREV)	90303	YES / NO	Allow clearing of stored rotation counts
CLEAR HOUR METER (CLRHRS)	90304	YES / NO	Allows clearing of hour meter
MAINTENANCE MESS. CLEAR (MANCLR)	90305		Allows for clearing of maintenance message time or entry of new time.

SETTING [display]	D.A.N NO.	OPTIONS [display] BOLD=DEFAULT	DESCRIPTION
REINITIAZE (REINIT)	99999	YES / NO	Reset indicator to factory default settings. 3
GAIN CALIBRATION (GN CAL)	100001		Enters gain calibration

SECTION 6 — INSTALLATION

6.1.0 Indicator Mounting

For most applications the equipment manufacturer provides the necessary mounting system and hardware, and mounts the Indicator for the End User.

Digi-Star provides a number of mounting options that allow the end user to customize the location and placement of the Indicator. The following section provides a list of the optional mounts.

In all cases the Digi-Star Indicator must be securely mounted to the equipment. Loose, or unsupported, Indicators can be damaged.

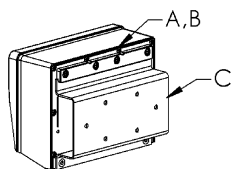

STD UNIVERSAL MOUNT TALL

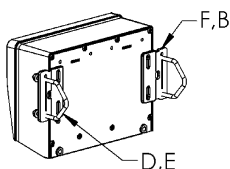

WING MOUNT

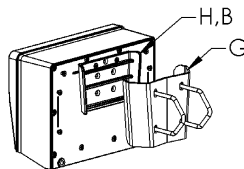

WEDGE MOUNT

KEY	PART NUMBER	DESCRIPTION
A	404353	BRACKET-EZ3 PLASTIC RAIL *
B	403780	SCR-#10 X 5/8 FHSTS BLACK ZP
C	840459	SUPPORT-HAT BRACKET
D	405069	U-BOLT 1/4-20 X 3.25 ZP
E	405084	NUT-1/4-20 TOP LOCKING FLANGE
F	403770	BRACKET- WING MOUNT *

G	405124	PACK-WEDGE MOUNT BRACKET WITH U-BOLTS & FLANGE NUTS
H	405244	EZ3 WEDGE MOUNT

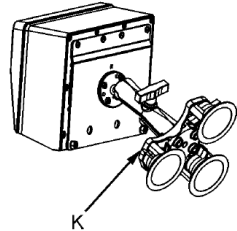
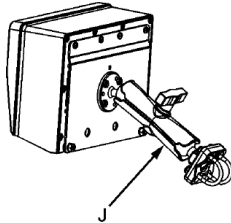
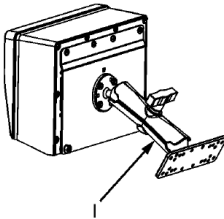

RAM MOUNT

KEY	PART NUMBER	DESCRIPTION
I	404799	KIT-1.5" RAM MOUNT WITH BOLT-ON BASE WITH HARDWARE
J	407544	KIT-1.5" RAM MOUNT WITH DUAL U-BOLTS (FITS 0.5"-1.5" ROUND)
K	407434	KIT-1.5" RAM MOUNT WITH TRIPLE SUCTION CUP BASE

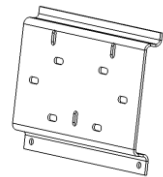
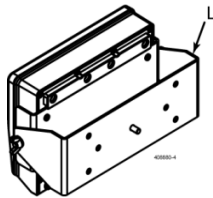
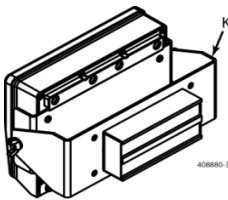

SIDE & UNIVERSAL MOUNTS

KEY	PART NUMBER	DESCRIPTION
K	408880	MOUNT FOR LARGE INDICATORS WITH HARDWARE AND MAGNET
L	408828	MOUNT FOR LARGE INDICATORS WITH HARDWARE WITHOUT MAGNET
M	408199	UNIVERSAL MOUNT SHORT

6.2.0 Cable Connections

For accurate and reliable operation care should be taken when routing and connecting cables to the Digi-Star Indicator.

- Cables should be secured and protected from damage and abrasion.
- Long cables should not “hang” by the cable connector at the Indicator but should be secured to a structure close to the Indicator leaving a short “tail” to connect to the Indicator

Special Considerations for Power (+) and Ground (-):

- The Digi-Star Indicator is designed to operate at a continuous voltage ranging from 10.5 to 16.0 volts.
- Intermittent voltage drops to as low as 9.0 volts, such as when starting an engine, will be tolerated. Continuous low voltage will result in a Low Voltage warning on the display or the Indicator will power off.
- Voltage spike above 16 volts will damage the Indicator. Never weld or charge the battery on the equipment that the Indicator is mounted to without disconnecting the Indicator power cord. Never operate an Indicator on equipment with an engine charging circuit when the battery has been removed.
- Digi-Star recommends that the red power (+) and black ground (-) are connected as follows:
- Power (+) can be either switched or keyed On & Off, or un-switched and always On.
- Power (+) and Ground (-) should come from a dedicated auxiliary power source when provided. When auxiliary power sources are not provided power should come from the main power distribution system.
 - Fuse or circuit protection of at least 5 amps, but no more than 10 amps, should be provided. Although the Indicator is protected internally by an internal fuse a fuse or circuit protection is required to protect the power cable and equipment.
 - Ground (-) connection should be made to a main ground (the battery ground (-) is often connected to this location). Do not use the chassis or frame of the equipment as a ground.

Scale Indicator

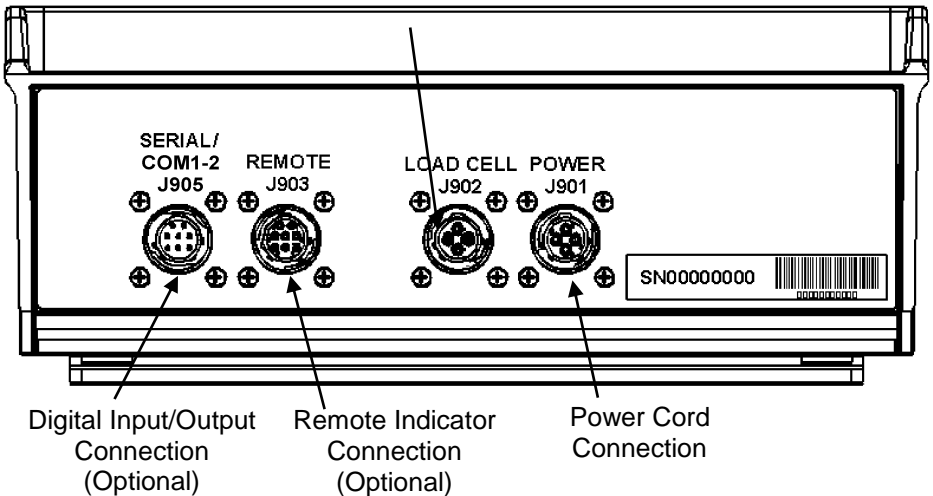
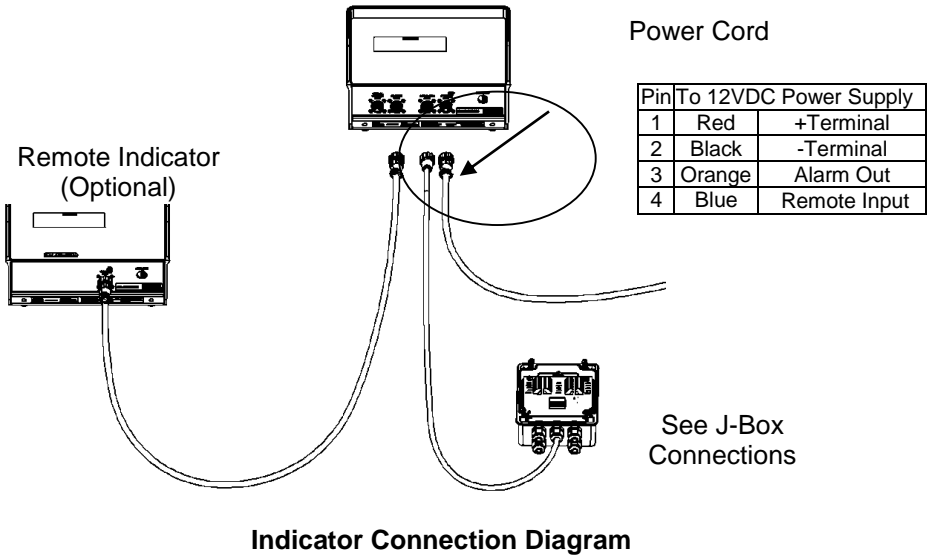

6.3.0 Connecting Load Cells to Junction Box

Connect load cell wires to terminal blocks. See Wire Color Key below.

Wire Color Key		
	Color	Description
1	White	Signal +
2	Green	Signal -
3	Red	Excitation +
4	Black	Excitation -
5	Shield	Shield

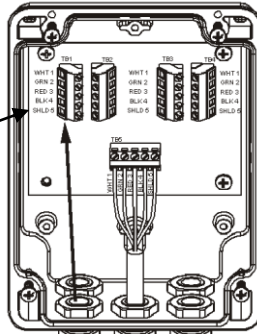

Junction Box Illustrated for 4 Load Cell Installation

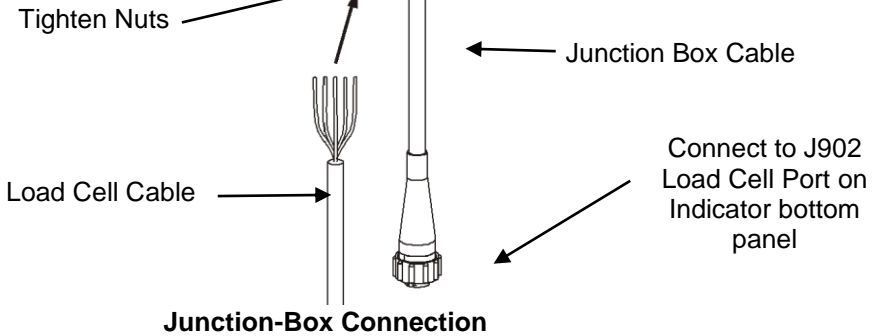

6.4.0 Load Cell Direction



Observe direction of arrow when installing or replacing load cells.

SECTION 7 - Optional Equipment

Digi-Star offers a wide range of optional equipment that can improve productivity, increase loading accuracy, and improve record keeping. Additional details can be found on the Digi-Star website at: www.digi-star.com

7.1.0 Cab Controls (Wireless)



Features

- Wireless Remote Display with full key control of Indicator on mixer
- Mount remote in easy view of loading
- Improves loading accuracy

Functions

- Mounts in cab of loader or across distance where wired remote is not practical.
- Will communicate with multiple mixers

Specifications

- Internally or Externally mounted 2.4 GHz & 900 MHz radios
- Ranges of 300', 1000', or 3 miles (90m, 300m, 5km).
- 24 channels
- 12 or 24 volt DC system

7.2.0 Remote Displays



- RD440 small backlit display with 1" tall numbers. (Not shown)
- RD2500V standard backlit display with 1.7" tall numbers
 - Optional wireless T/R available. Allows user to remote Tare or Advance Indicator
- RD4000 LED ultra-bright display with 4" tall letters. (Not shown)

7.3.0 Transmitter/Receiver



Transmitter (shown) with factory installed receiver in indicator. Use to zero indicator from a remote location. Operating range up to 90' (27 m).

7.4.0 Printer Option



7.5.0 Data Transfer Options



Kit Data Down Loader (DDL)

Allows transfer of data from Indicator to PC. (Optional Serial communication port must already be installed in indicator)

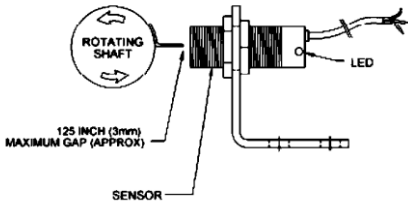
7.5.0 Rotation Counter Sensor (Kit p/n: 408088)

Use with Indicator for: Timer,
Rotation, Hour Meter, or
Maintenance Message functions.

FLOW CHART

Continued

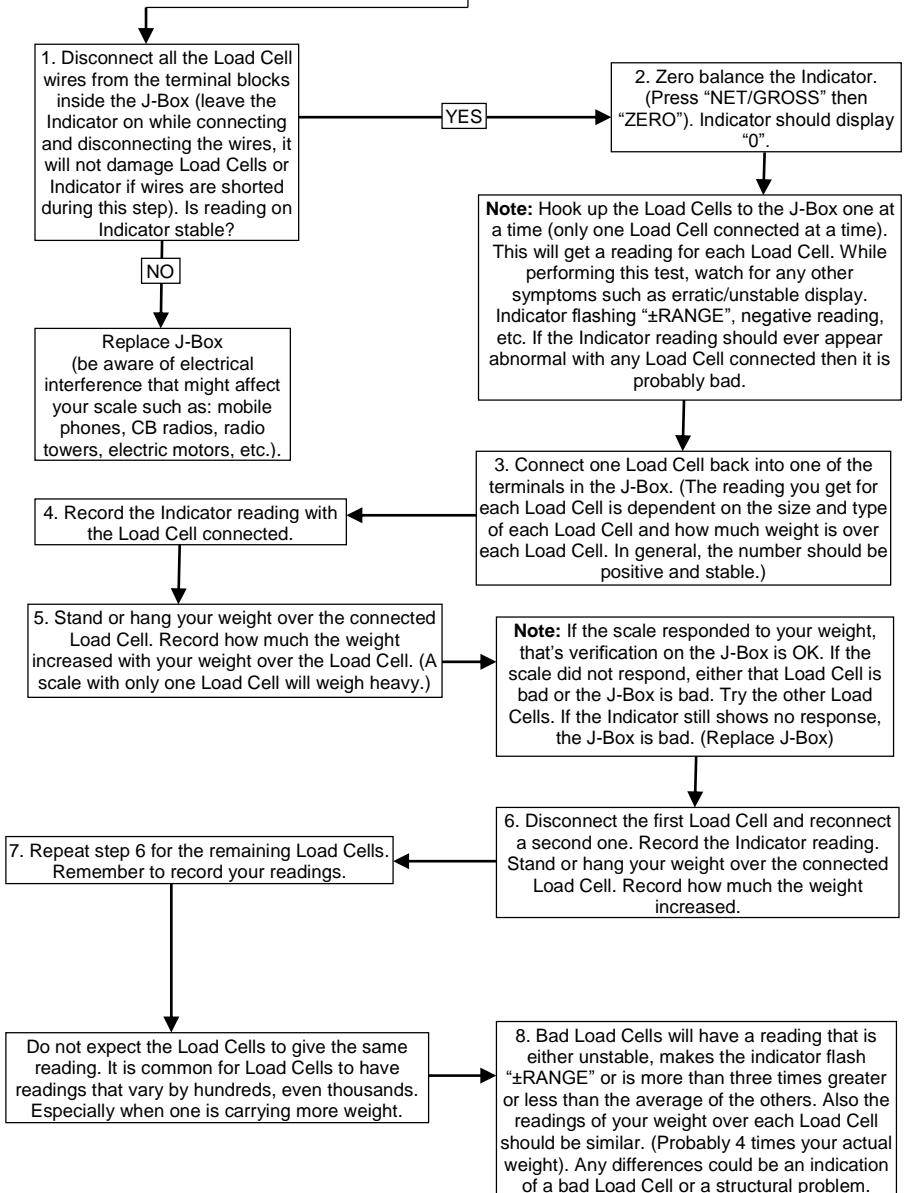

SECTION 9 – Declarations & Certificates

9.1.0 Declaration of Conformity (EU)

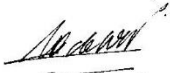
EMC DECLARATION OF CONFORMITY			
Application of Council Directive(s) <u>2004/108/EC</u>			
Manufacturer's Name:	Digi-Star, LLC		
Manufacturer's Address:	W5527 State Hwy 106 Fort Atkinson, WI 53538		
European Representative Name:	Digi-Star International		
European Representative Address:	J.F. Kennedylaan 235 5981 WX Panningen The Netherlands		
Model Name:	TMR3610, EZ2810		
Conformance to:	§ EN 61326-1 electrical equipment for measurement, control, and laboratory use (See Report Number 314363.) § EN 55011, for Class B ISM equipment for industrial, scientific, and medical equipment. (See Report Number 314363.)		
Equipment Type/Environment:	Electronic weighing scale systems; not legal for trade. For agricultural, commercial and industrial use.		
Beginning Serial No.:	00001001		
Year of Manufacture:	2015		
We, the undersigned, hereby declare that the equipment specified above conforms to the above Directive(s).			
Manufacturer	Legal Representative in Europe		
			
Signature	Signature		
Full Name:	Steven Gorseth	Full Name:	Wim de Wit
Position:	Director of Engineering	Position:	Managing Director
Place:	Fort Atkinson, WI U.S.A.	Place:	Panningen, The Netherlands
Date:	Jan 23, 2015	Date:	Jan 23, 2015

9.2.0 Legal-for-Trade Certification

Not presently available

NOTES